

Regulatory Investment Test for Distribution



Non-Network Options Report

Planella Substation Reinforcement

This document describes the *identified need* for investment at Planella. It includes description of the likely network options and to the extent possible, the characteristics of non-network options which may, either alone or in combination with network or other non-network options, represent a feasible solution for addressing the identified need.

Consultation Period Starts: **24 June 2019**

Consultation Period Closes: **19 September 2019**

Disclaimer

While care was taken in preparation of the information in this **Non Network Options Report**, and it is provided in good faith, Ergon Energy Corporation Limited accepts no responsibility or liability for any loss or damage that may be incurred by any person acting in reliance on this information or assumptions drawn from it. This document has been prepared for the purpose of inviting information, comment and discussion from interested parties. The document has been prepared using information provided by a number of third parties. It contains assumptions regarding, among other things, economic growth and load forecasts which may or may not prove to be correct. All information should be independently verified to the extent possible before assessing any investment proposal

Executive Summary

Ergon Energy Corporation Limited (Ergon Energy) is responsible (under its Distribution Authority) for electricity supply to the Mackay northern beaches area in North Queensland.

Planella (PLAN) 33/11 kV Zone Substation is located in the suburb of Rural View on the northern beaches of Mackay, and the substation services the Mackay northern beaches suburbs of Shoal Point, Bucasia, Eimeo, Dolphin Heads, Blacks Beach and Rural View. This area is primarily a residential area, and the surrounding suburbs are highlighted in the Mackay Regional Council regional planning scheme strategic framework for growth over the next 15 years.

Planella substation presently supplies 6,162 customers and has two 13 MVA 33/11 kV OLTC transformers which have both an N-1 transformer cyclic and long term emergency cyclic rating of 15.3 MVA. The substation is presently supplied via a single circuit radial 33 kV sub-transmission line which is teed off the line from Glenella (GLEL) 66/33/11 kV substation to North Mackay (NOMA) 33/11 kV substation just outside North Mackay substation.

Planella does not have N-1 security and is reliant on the 33 kV radial feeder between North Mackay and Planella. Currently a fault on this section of line will result in an outage for all Planella customers which combine for a peak load at risk of approximately 15.85 MVA.

Planella does not comply with the Safety Net requirements based on credible contingencies benchmarked against 50% PoE load in the present configuration.

Under most circumstances, the wood poles of the 33 kV Planella tee – Planella sub-transmission line are accessible; however in the event of periods of heavy rainfall and/or king tides, sections of the line passing through mangrove wetlands become virtually inaccessible.

For the loss of the incoming 33 kV feeder, resulting from a pole failure or wires on ground in an inaccessible location, the customer outage duration would be greater than 12 hours hence supply restoration is not Safety Net compliant for this scenario.

Ergon Energy's preferred internal solution at this stage is to:

- Rebuild a 1.5 km section of the existing 33 kV feeder in the storm tide inundation flood zone using concrete pole construction, obtain easements & develop additional 11 kV feeder ties.

This is a Non-Network Options Report, where Ergon Energy is seeking information about possible solutions to address the identified need, which may be able to be provided by parties other than Ergon Energy.

Submissions in writing (electronic preferably) are due by **19 September 2019** and should be lodged to Ergon Energy's "Regulatory Investment Test for Distribution (RIT-D) Partner Portal". The portal is available at:

<https://www.ergon.com.au/network/network-management/network-infrastructure/regulatory-test-consultations>

For further information and inquiries please refer to the "Regulatory Investment Test for Distribution (RIT-D) Partner Portal".

Table of Contents

Executive Summary	1
Table of Contents.....	2
List of Figures and Tables	3
1. Introduction.....	4
2. Background.....	5
2.1. Geographic Region.....	5
2.2. Existing Supply System	7
3. Identified Need.....	8
3.1. Description of the Identified Need	8
3.1.1. Safety Net Non-Compliance.....	8
3.2. Quantification of the Identified Need	8
3.2.1. NOMA-PLAN 33 kV Feeder Route (Flood Zone).....	8
3.2.2. Safety Net Non-Compliance.....	9
4. Value of Customer Reliability	9
5. Load Profiles.....	11
5.1. Planella (PLAN) 33/11 kV Substation.....	11
5.1.1. Historical Load Growth.....	11
5.1.2. Rooftop Solar PV Capacity Growth.....	11
5.1.3. Base Growth Scenario Forecast	12
5.1.4. High Growth Scenario Forecast	12
5.1.5. Full Annual Load Profile for Planella Substation.....	13
5.1.6. Average Peak Weekday Load Profile (Summer)	14
5.1.7. Load Duration Curve for Planella Substation	14
6. Assumptions in Relation to Identified Need.....	15
6.1. Forecast Maximum Demand	15
6.2. Load Profile	15
6.3. System Capability – Line Ratings.....	15
7. Technical Characteristics of Non-Network Options	16
7.1. Size	16
7.2. Location.....	16
7.3. Timing.....	16
7.3.1. Implementation Timeframe	16
7.3.2. Time of Year	16
7.3.3. Duration.....	16
7.4. Compliance with Regulations & Standards	17

7.5. Longevity	17
8. Feasible vs Non Feasible Options.....	17
8.1. Potentially Feasible Options.....	17
8.2. Options that are Unlikely to be Feasible.....	17
9. Internal Options Identified	18
9.1. Non-Network Options Identified	18
9.2. Distribution Network Options Identified	18
10. Submissions & Next Steps	18
10.1. Submissions from Solution Providers	18
10.2. Next Steps.....	19

List of Figures and Tables

Figure 1: Mackay Northern Beaches 33 kV Sub-transmission Network.....	5
Figure 2: Residential Land Zoning in the Mackay Northern Beaches Area.....	6
Figure 3: Existing 33 kV Sub-transmission Network.....	7
Figure 4: North Mackay Storm Tide Inundation Map	8
Figure 5: Safety Net Analysis for PLAN (Loss of 33 kV Feeder in Inaccessible Location)	9
Figure 6: Unserved Energy VCR Values due to Lack of N-1 at PLAN (Actuals)	10
Figure 7: Historical Load of Planella Substation (Since 2004)	11
Figure 8: Forecast Rooftop Solar PV Capacity for Planella Substation.....	12
Figure 9: Forecast 50% POE Load for Planella Substation (Base Case Scenario).....	12
Figure 10: Forecast 50% POE Load for Planella Substation (High Growth Scenario)	13
Figure 11: Full Annual Load Profile for Planella Substation.....	13
Figure 12: Average Peak Weekday Load Profile (Summer)	14
Figure 13: Load Duration Curve for Planella Substation.....	14
Table 1: Planella Substation Customer Breakdown	10
Table 2: AEMO VCR Values for Different Customer Types	10
Table 3: Line Rating Parameters.....	15
Table 4: Demand Reduction Required.....	16
Table 5: Ergon Energy's Internal Cost for the Preferred Option.....	18

1. Introduction

This Non Network Options Report has been prepared by Ergon Energy in accordance with the requirements of clause 5.17.4(e) of the National Electricity Rules (NER).

This report represents the first stage of the consultation process in relation to the application of the Regulatory Investment Test for Distribution (RIT-D) on potential credible options to address the identified limitations in the distribution network that supplies the Mackay northern beaches area.

This report:

- Provides background information on the network capability limitations of the distribution network supplying the Mackay northern beaches area.
- Identifies the need which Ergon Energy is seeking to address, together with the assumptions used in identifying and quantifying that need.
- Describes the credible options that Ergon Energy currently considers may address the identified need, including for each:
 - Its technical definitions;
 - The estimated commissioning date; and
 - The total indicative cost (including capital and operating costs).
- Sets out the technical characteristics that a non-network option would be required to deliver in order to address the identified need.
- Is an invitation to registered participants and interested parties to make submissions on credible options to address the identified need.

In preparing this RIT-D, Ergon Energy is required to consider reasonable future scenarios. With respect to possible future loads and development, Ergon Energy has, in good faith, included as much detail as possible while maintaining necessary customer confidentiality. At the time of writing, Ergon Energy considers the most probable future scenario to be that there will be significant future development in the Mackay northern beaches area, and has developed this Non Network Options Report (including *Internal Options*) principally on this basis. It is noted that customer activity can occur over the consultation period and may change the timing and/or scope of any proposed solutions.

Submissions in writing (electronic preferably) are due by **19 September 2019** and should be lodged to Ergon Energy's "Regulatory Investment Test for Distribution (RIT-D) Partner Portal". The portal is available at:

<https://www.ergon.com.au/network/network-management/network-infrastructure/regulatory-test-consultations>

For further information and inquiries please refer to the "Regulatory Investment Test for Distribution (RIT-D) Partner Portal".

2. Background

2.1. Geographic Region

The geographic region covered by this RIT-D is the Planella substation and surrounding 33 kV sub-transmission network.

Planella (PLAN) 33/11 kV Zone Substation is located in the suburb of Rural View on the northern beaches of Mackay. Planella substation services the Mackay northern beaches suburbs of Shoal Point, Bucasia, Eimeo, Dolphin Heads, Blacks Beach and Rural View. This area is primarily a residential area, consists of approximately 6,162 customers and is located in the Mackay area of the Northern Region of Ergon Energy’s Network.

The geographical location of Ergon Energy’s 33 kV sub-transmission network and substations in the Mackay northern beaches area is illustrated in the Google Earth image below.

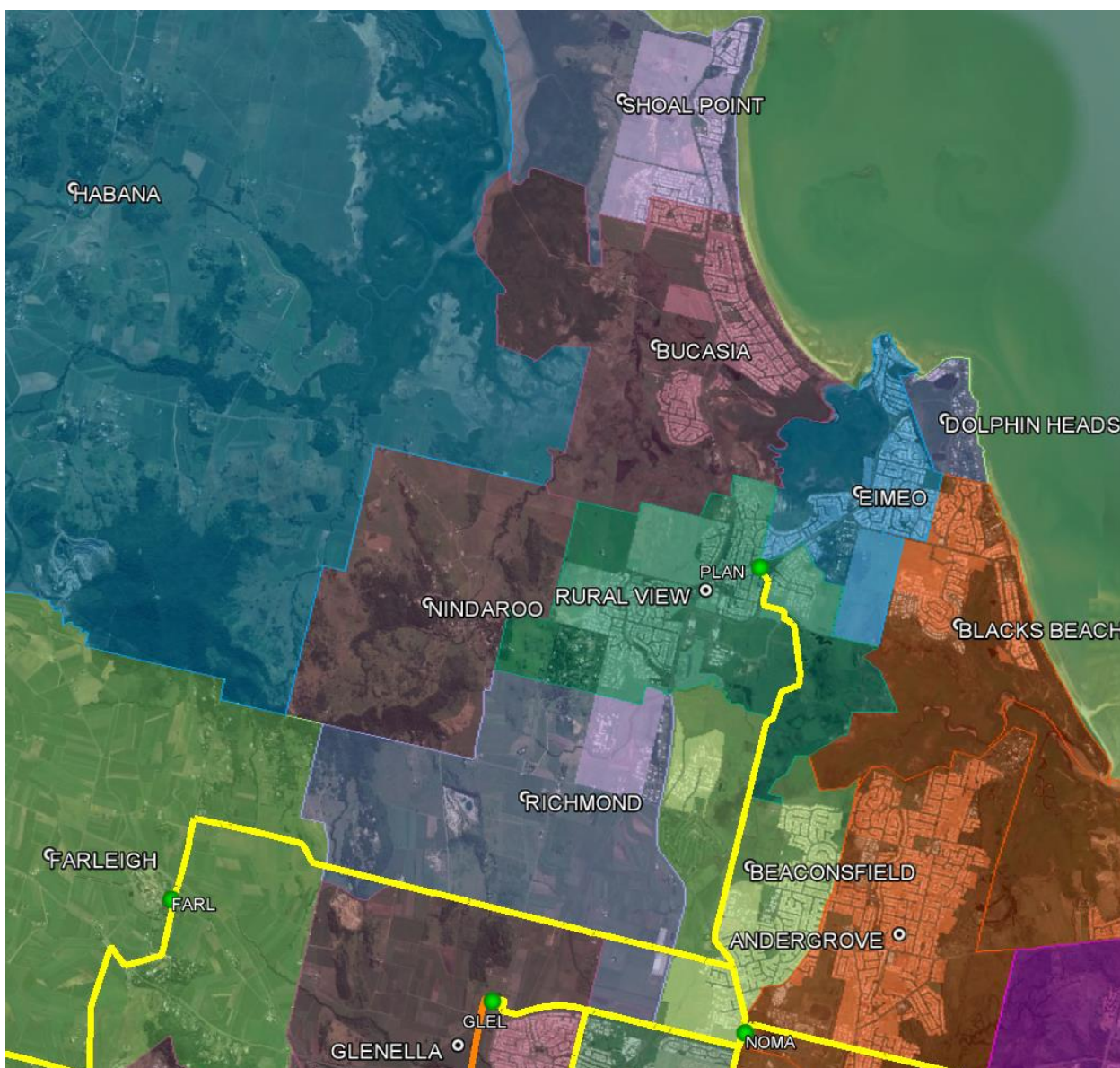

Figure 1: Mackay Northern Beaches 33 kV Sub-transmission Network

The Mackay northern beaches area and the surrounding suburbs are highlighted in the Mackay Regional Council regional planning scheme strategic framework for growth over the next 15 years. There are a number of approved large subdivisions in various stages of implementation such as Plantation Palms Estate, Richmond Hills Estate, Royal Sands Estate and Kerrisdale Estate. The concentration of building activity in the area represents significant load growth to the network over the next 15 years.

Illustrated below is a map showing the areas that are currently zoned for residential development in the northern beaches area. It can be noted that the majority of the new development areas for residential growth are in the vicinity of Planella substation.

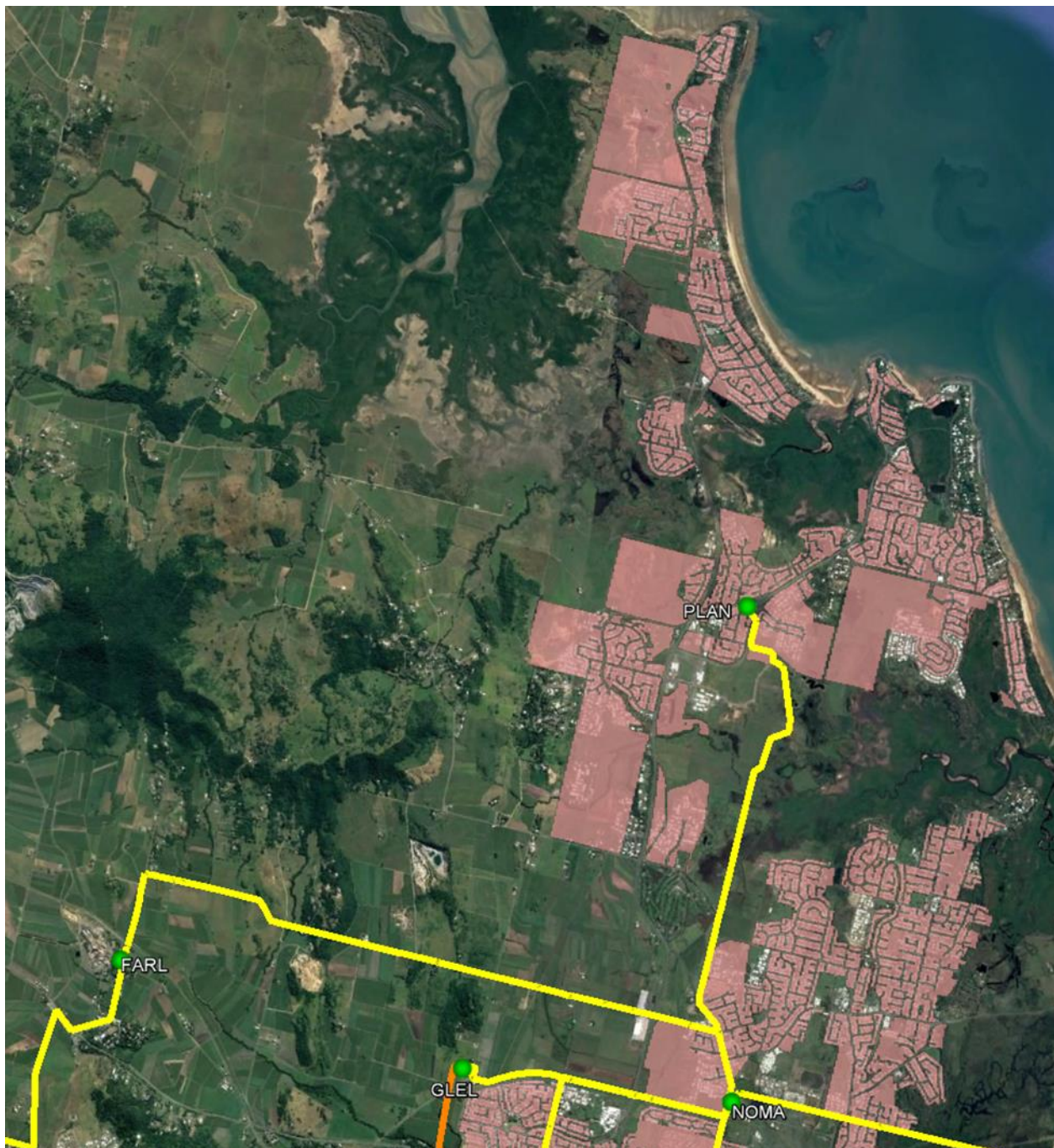

Figure 2: Residential Land Zoning in the Mackay Northern Beaches Area

2.2. Existing Supply System

The Mackay northern beaches area is supplied from Planella (PLAN) 33/11 kV zone substation.

Planella (PLAN) substation presently supplies 6,162 customers and has two 15 MVA 33/11 kV transformers which both have an N-1 transformer cyclic and long term emergency cyclic rating of 15.3 MVA. Planella substation supplies six 11 kV distribution feeders which contain four existing 11 kV feeder ties to 11 kV feeders supplied from North Mackay 33/11 kV substation (NOMA).

Planella substation is supplied via a single circuit radial 33 kV sub-transmission line (FDR 340) which is teed off the line from Glenella (GLEL) 66/33/11 kV substation to North Mackay (NOMA) 33/11 kV substation (FDR 422) just outside North Mackay substation. There is also an additional tee-off, approximately 7.7 km in length, to Farleigh (FARL) 33/11 kV substation that is operated with a normally open gas switch near the tee-off point. The tee-off is located approximately 800 m from North Mackay substation.

The 3.3 km 33 kV section from Glenella to North Mackay is predominantly 630mm² Cu XLPE cable with a single span (64 m) of Pluto 19/3.75 AAC conductor adjacent to North Mackay substation. The rating of this section is limited by the span of Pluto conductor which has a summer day rating of 35.8 MVA.

The 6.1 km 33 kV section from North Mackay to Planella is predominantly timber pole construction with no overhead earth wire. The feeder section predominantly consists of approximately 0.66 km of Jasper 7/4.75 AAAC conductor, 4.46 km of Cherry 6/4.75-7/1.60 ACSR/GZ conductor and 0.87 km of Iodine 7/4.75 AAAC conductor. The rating of this section is limited by the Cherry conductor which has a summer day rating of 21 MVA.

The existing 33 kV network arrangement is shown schematically in the figure below.

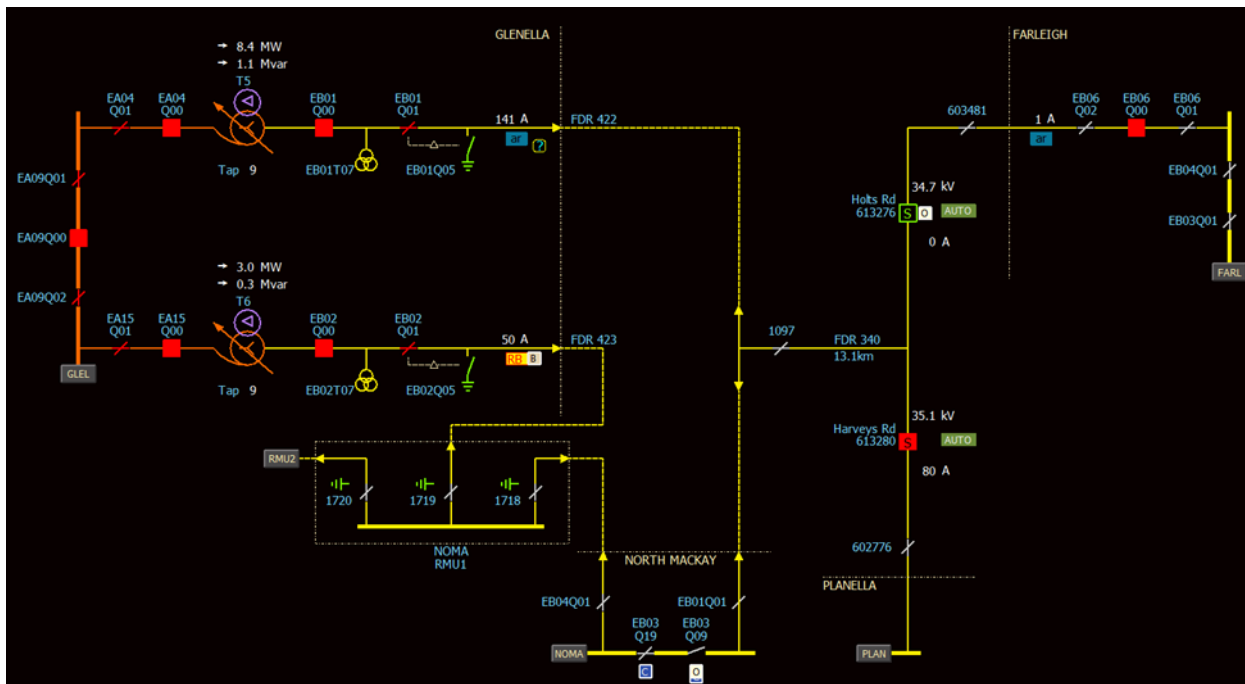

Figure 3: Existing 33 kV Sub-transmission Network

3. Identified Need

3.1. Description of the Identified Need

3.1.1. Safety Net Non-Compliance

Due to the existing sub-transmission network configuration, Planella does not have N-1 security and is reliant on the 33 kV radial feeder between North Mackay and Planella. Currently a fault on this section of line will result in an outage for all Planella customers which combine for a peak load at risk of approximately 15.85 MVA.

Planella does not comply with the Safety Net requirements based on credible contingencies benchmarked against 50% PoE load in the present configuration.

3.2. Quantification of the Identified Need

3.2.1. NOMA-PLAN 33 kV Feeder Route (Flood Zone)

The existing radial 33 kV wood pole line between North Mackay and Planella currently runs through a low lying area that is prone to flooding due to storm tide inundation. During periods of heavy rainfall and/or king tides, sections of the line route are inaccessible and normal restoration times for credible contingencies are not achievable.

The figure below shows the area along the feeder route that is affected by storm tide inundation.

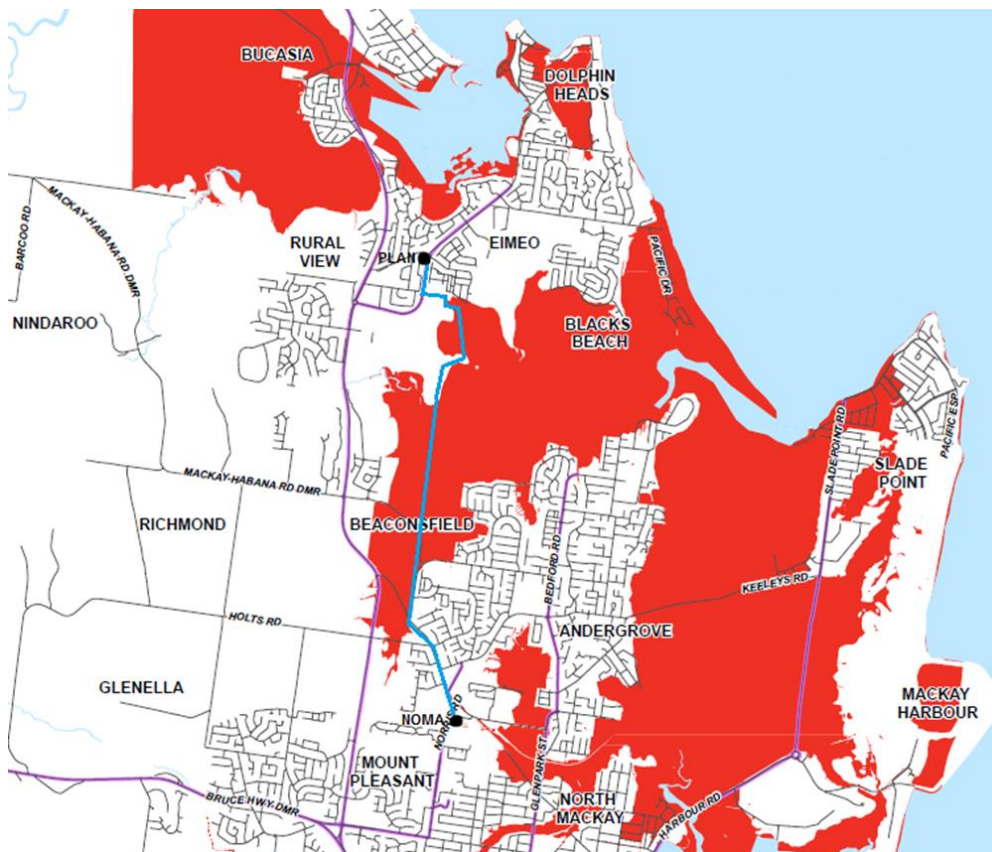

Figure 4: North Mackay Storm Tide Inundation Map

3.2.2. Safety Net Non-Compliance

Under most circumstances, the wood poles of the 33 kV Planella tee – Planella sub-transmission line are accessible; however in the event of periods of heavy rainfall and/or king tides, sections of the line passing through low lying areas become virtually inaccessible.

For the loss of the incoming 33 kV feeder, resulting from a pole failure or wires on ground in an inaccessible location, the customer outage duration would be greater than 12 hours hence supply restoration is not Safety Net compliant for this scenario.

Under this scenario it is possible to transfer up to 2.3 MVA of load to NOMA via Celeber Drive feeder via manual field switching within 2 to 3 hours. Fault finding, switching, repairs and restoration would be expected to take between 19 to 48 hours depending on the type of fault and the fault location.

This is reflected in the figure below.

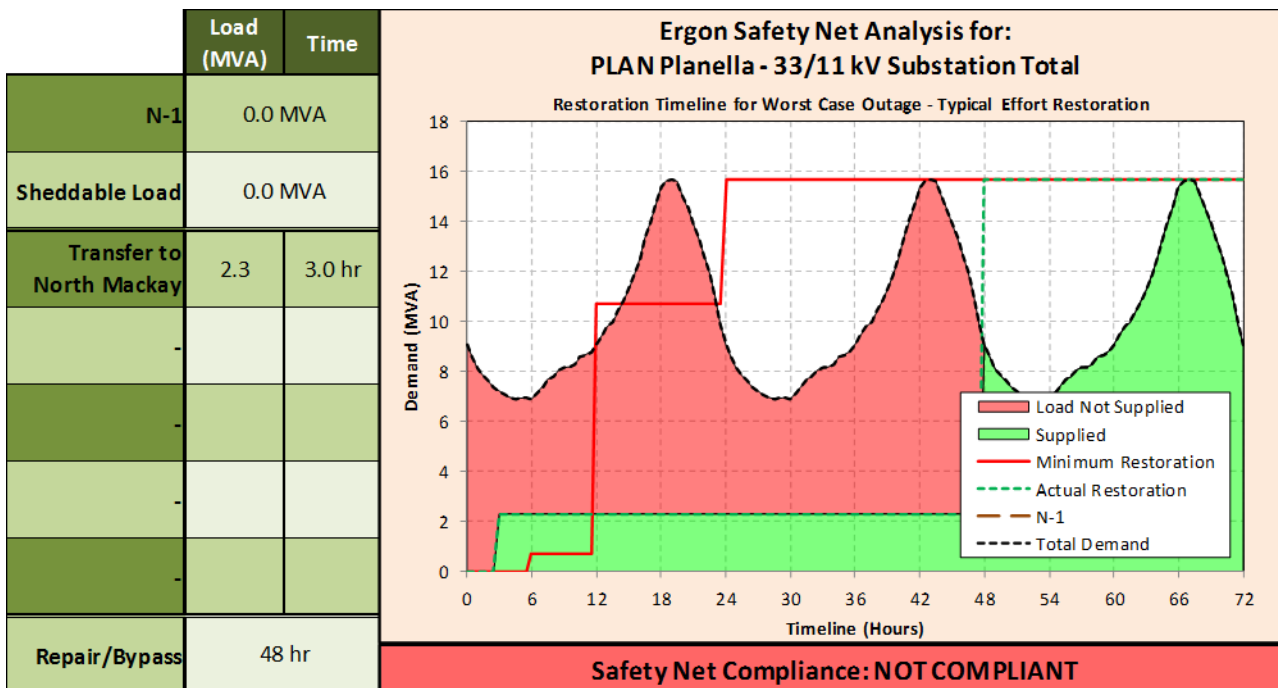

Figure 5: Safety Net Analysis for PLAN (Loss of 33 kV Feeder in Inaccessible Location)

4. Value of Customer Reliability

Value of Customer Reliability (VCR) is an economic value applied to customers’ unserved energy for any particular year. Any reduction in unserved energy a solution that addresses the identified need described in Section 3 will bring will be treated as a benefit based on the corresponding reduction in customer financial consequence.

Based on historical reliability performance of the 33 kV sub-transmission network in the Mackay northern beaches area, forecast load growth and load duration; probability weighted values of

unserved energy at Planella have been calculated. These values have been converted into a dollar figure which reflects the customer financial consequence of the unserved energy.

Customer impact of the sub-transmission network configuration has fluctuated substantially in the last nine years. This is reflected in the Value of Customer Reliability (VCR) values based on analysis of historical outages over the past nine years as shown in the figure below.

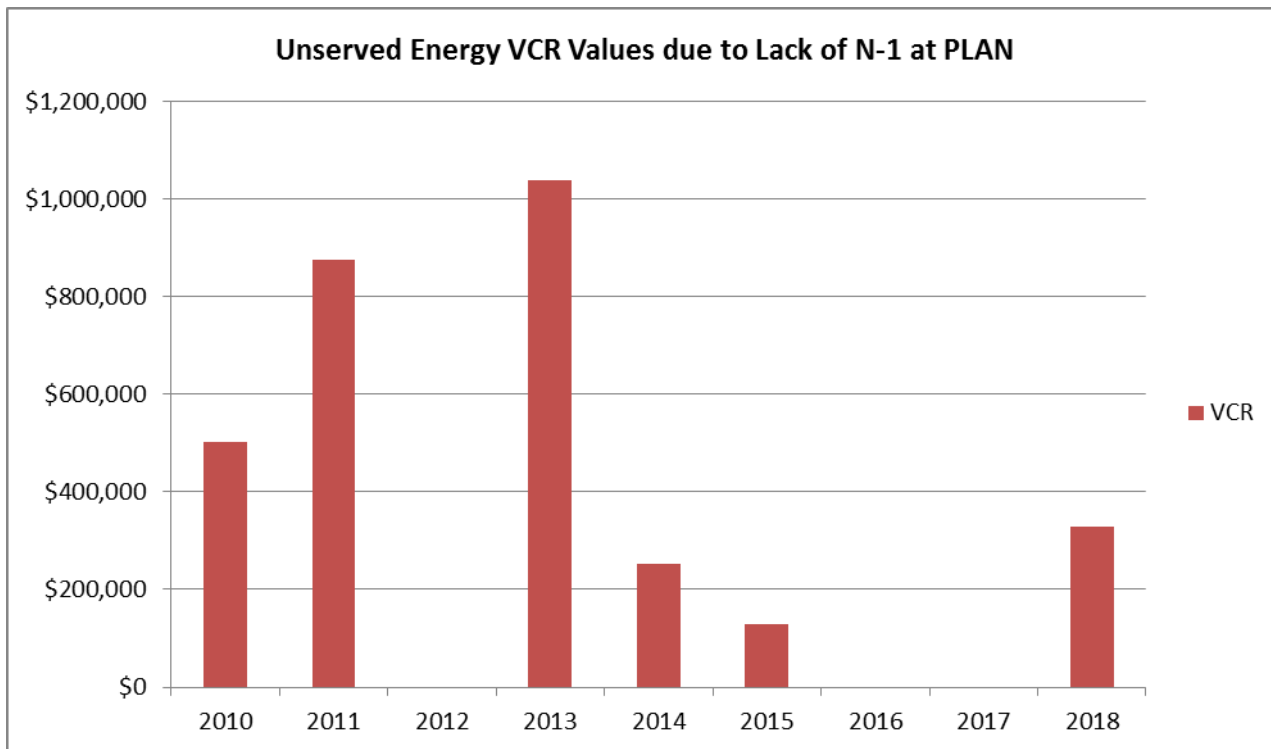

Figure 6: Unserved Energy VCR Values due to Lack of N-1 at PLAN (Actuals)

The unit rate for Value of Customer Reliability that has been used for this analysis is \$26/kWh. This is a location specific value for Planella based on the customer mix shown in Table 1 and the VCR values for different customer types shown in Table 2 as published by AEMO.

Table 1: Planella Substation Customer Breakdown

Feeder	Number of Premises	Domestic Premises	Commercial Premises	Industrial Premises
Eimeo	1,557	1,511	0	46
Bucasia	1,287	1,252	0	35
Rural View	1,585	1,530	0	55
Blacks Beach	1,662	1,630	0	32
Rosewood Dr	71	48	0	23
Chenoweth	0	0	0	0
Total	6,162	5,971	0	191

Table 2: AEMO VCR Values for Different Customer Types

Sector	\$/kWh	VCR (\$/MWh)
Domestic	\$25.42	\$25,420
Commercial	\$44.72	\$44,720
Industrial	\$44.06	\$44,060
Rural	\$47.67	\$47,670

5. Load Profiles

5.1. Planella (PLAN) 33/11 kV Substation

The load at Planella comprises a mix of residential and commercial customers. Daily peak loads generally occur in the late afternoon and evening. The load is summer peaking, and annual peak loads are predominantly driven by air-conditioning.

5.1.1. Historical Load Growth

The historical load of Planella substation for the summer day (SD), summer night (SN), winter day (WD) and winter night (WN) periods since 2003 is shown in the figure below.

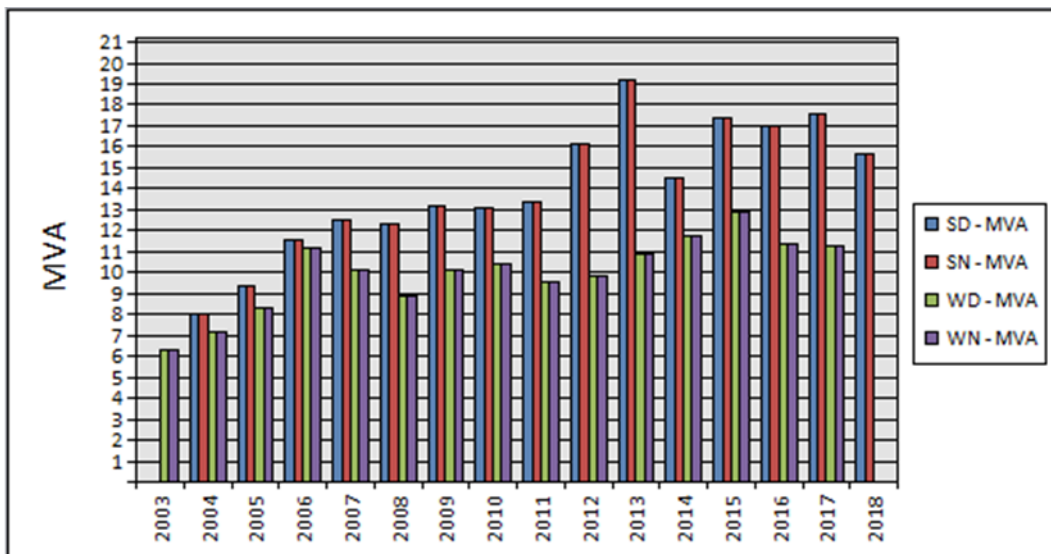

Figure 7: Historical Load of Planella Substation (Since 2004)

It should be noted that the reduction from the peak of 2013 (19.2 MVA) to the peak of 2018 (15.85 MVA) was due to a combination of reduced housing occupancy, reduced housing growth rate, a significant increase in rooftop solar PV and the establishment of additional 11 kV feeder ties which enabled the permanent transfer of load across to North Mackay (NOMA) substation.

5.1.2. Rooftop Solar PV Capacity Growth

The figure below shows the forecast rooftop solar PV capacity growth in the Planella supply area under low (5.8%), moderate (9.4 %) and high (13.3 %) growth rates. From this it is evident that load growth will continue to be somewhat held back by the growth of connected PV in the region.

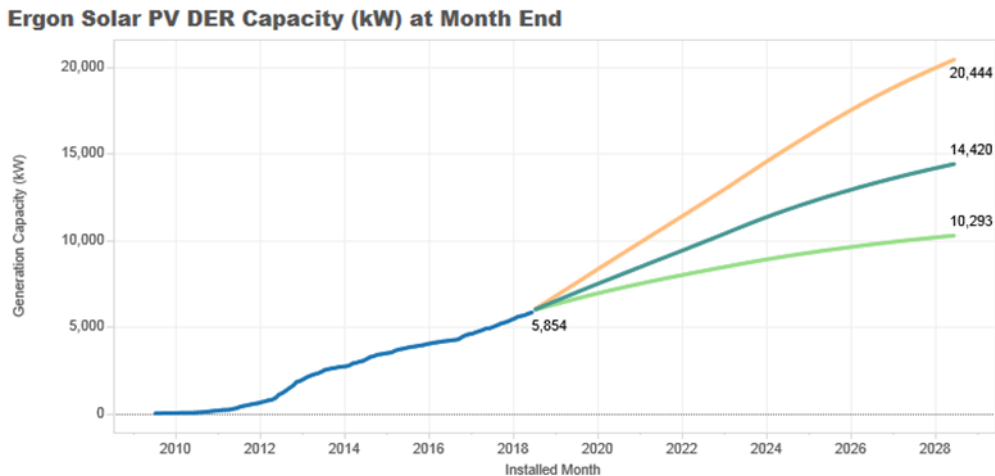

Figure 8: Forecast Rooftop Solar PV Capacity for Planella Substation

5.1.3. Base Growth Scenario Forecast

The 50% POE load forecast for the base growth scenario for Planella substation out until 2028 is illustrated in the figure below.

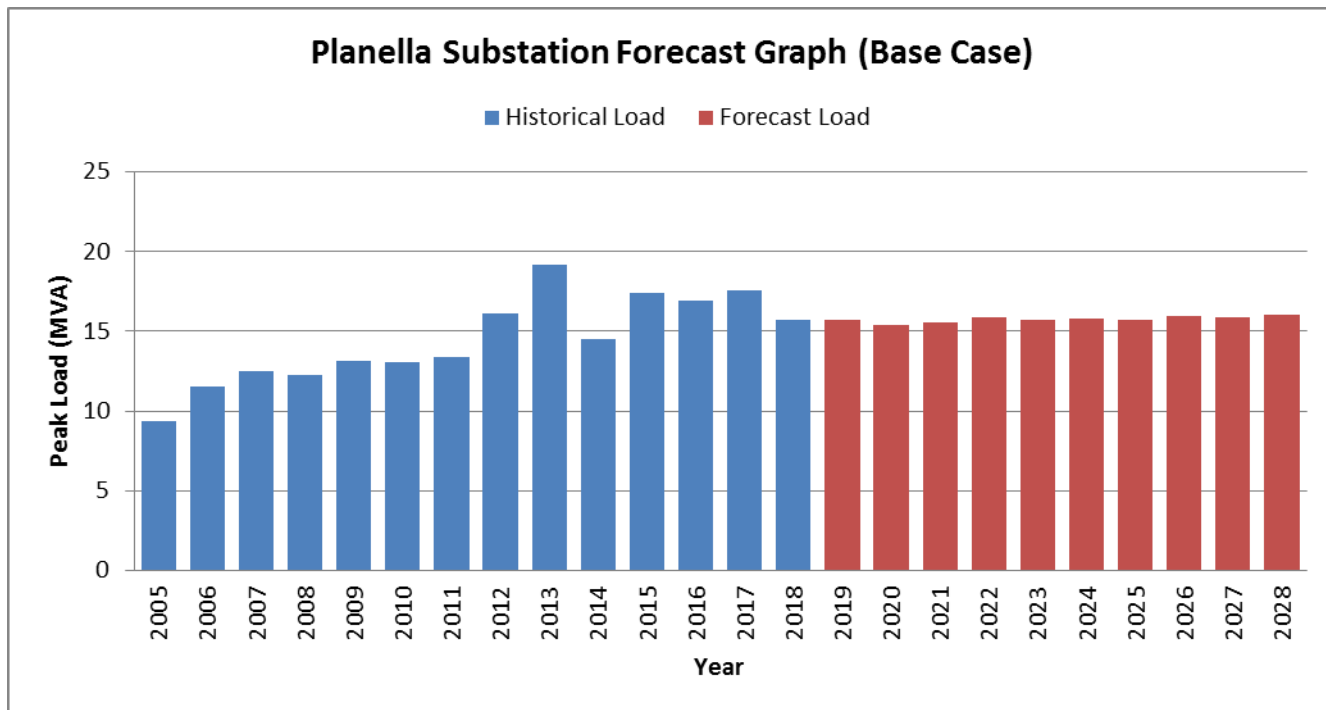

Figure 9: Forecast 50% POE Load for Planella Substation (Base Case Scenario)

5.1.4. High Growth Scenario Forecast

The 50% POE load forecast for the high growth scenario for Planella substation out until 2028 is illustrated in the figure below.

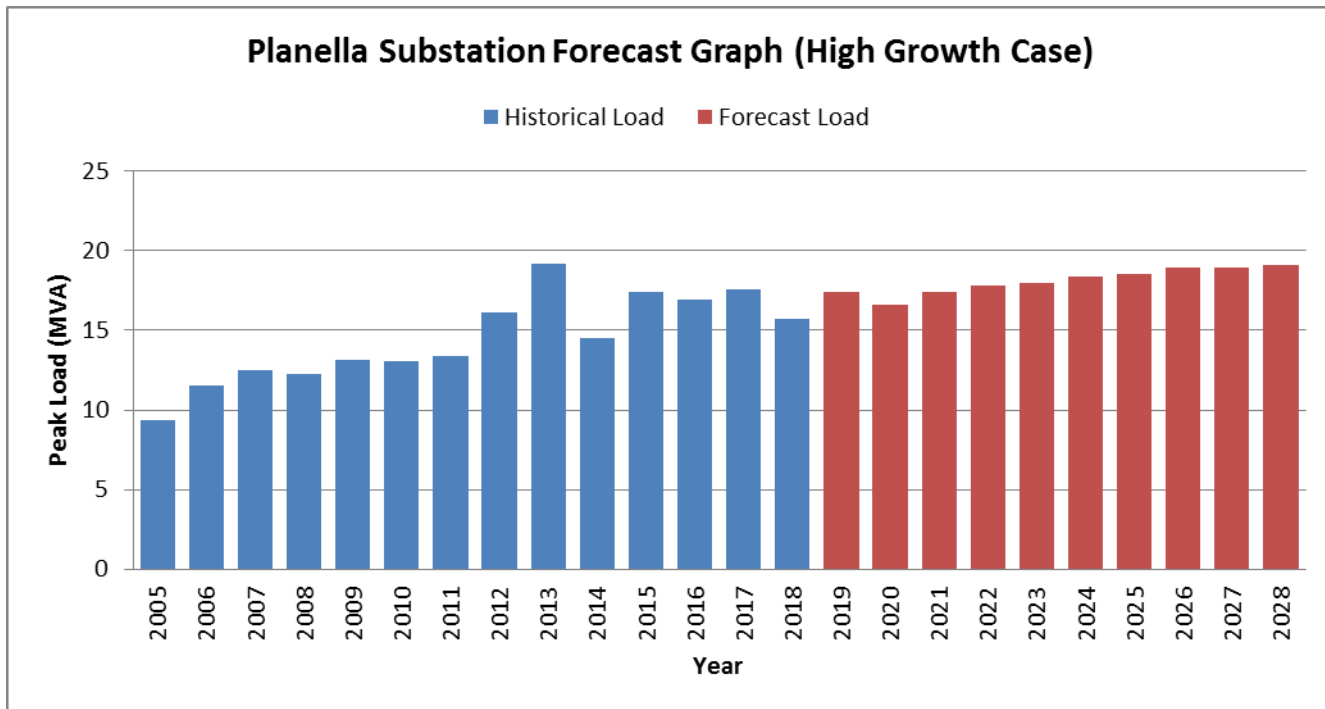

Figure 10: Forecast 50% POE Load for Planella Substation (High Growth Scenario)

5.1.5. Full Annual Load Profile for Planella Substation

The full annual load profile for Planella substation is illustrated in the figure below. It should be noted that peak load occurs during summer at Planella substation.

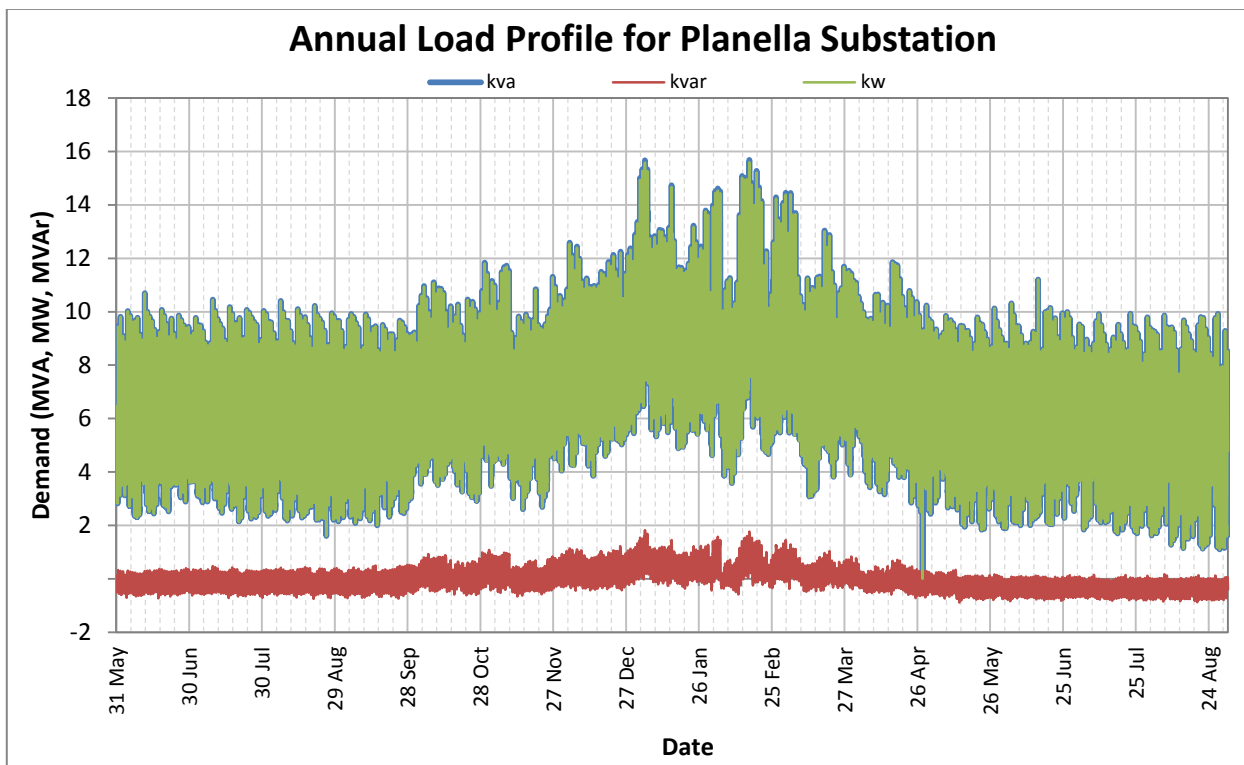

Figure 11: Full Annual Load Profile for Planella Substation

5.1.6. Average Peak Weekday Load Profile (Summer)

The daily load profile for an average peak weekday during summer at Planella substation is illustrated in the figure below. It should be noted that the Planella substation summer peak loads were being experienced in the late afternoon and evening.

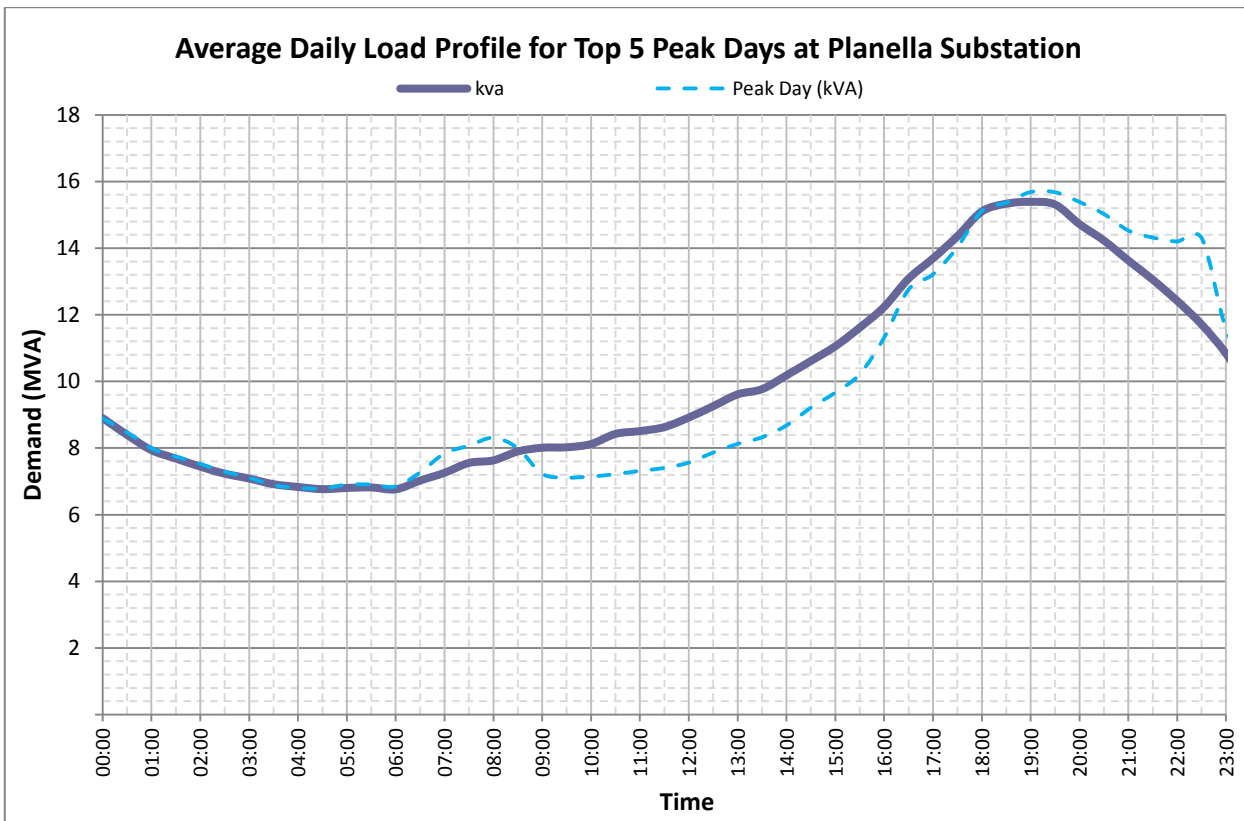

Figure 12: Average Peak Weekday Load Profile (Summer)

5.1.7. Load Duration Curve for Planella Substation

The load duration curve for Planella substation is illustrated in the figure below.

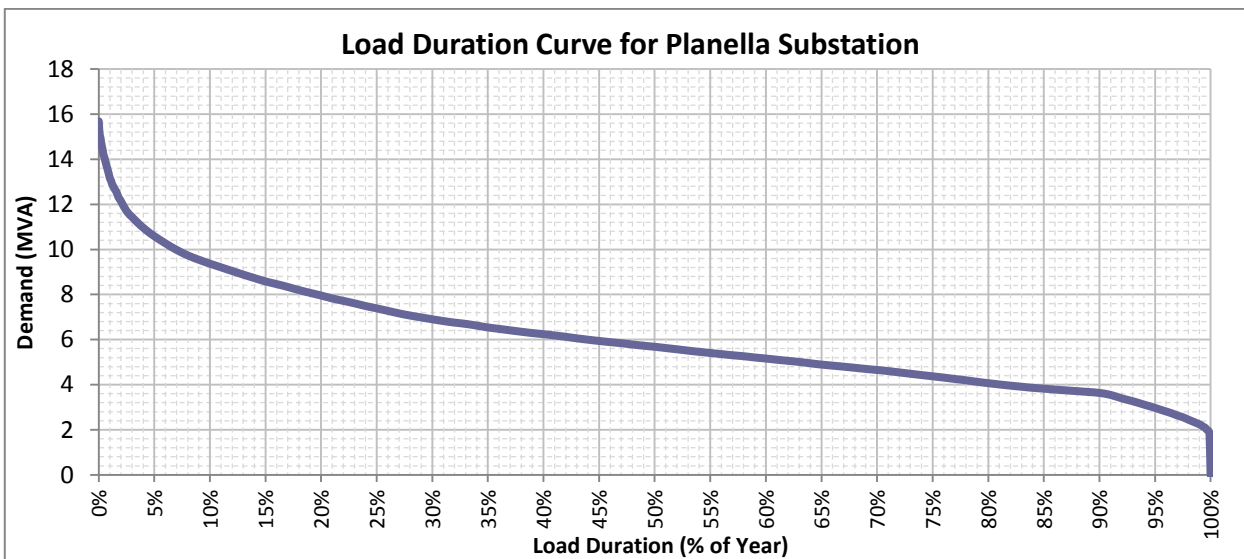

Figure 13: Load Duration Curve for Planella Substation

6. Assumptions in Relation to Identified Need

Below is a summary of key assumptions that have been made when the Identified need has been analysed and quantified.

It is recognised that the below assumptions may prove to have various levels of correctness, and they merely represent a ‘best endeavours’ approach to predict the future identified need.

6.1. Forecast Maximum Demand

It has been assumed that peak demand at Planella substation will grow as forecasted.

Factors that have been taken into account when the load forecast has been developed include the following:

- load history
- known future developments (new major customers, network augmentation, etc.)
- temperature corrected start values (historical peak demands)
- forecast growth rates for organic growth

6.2. Load Profile

Characteristic peak day load profiles shown in Section 5 are unlikely to change significantly from year to year, i.e. the shape of the load profile will remain virtually the same with increasing maximum demand.

6.3. System Capability – Line Ratings

The 33 kV line from North Mackay to Planella is predominantly timber pole construction with no overhead earth wire. The rating of this line is limited by the Cherry conductor which has a summer day rating of 21 MVA.

The thermal ratings of the sub-transmission line that supplies Planella have been calculated based on the main parameters listed in the table below.

Table 3: Line Rating Parameters

Parameter	Summer Day (9am – 5pm)	Summer Evening (5pm – 10pm)
Ambient Temperature	35°C	31°C
Wind Velocity	1.3 m/s	0.8 m/s
Wind Angle to Conductor Axis	45°	45°
Direct Solar Radiation	910 W/m ²	200 W/m ²
Diffuse Solar Radiation	210 W/m ²	20 W/m ²

7. Technical Characteristics of Non-Network Options

This section describes the technical characteristics of the identified need that a non-network option would be required to comply with.

7.1. Size

To meet Ergon Energy's ongoing operational needs it is expected that any alternate solution must provide stand-alone supply to the distribution network that supports a load up to the values listed in the table below.

Table 4: Demand Reduction Required

Year	Demand Reduction Required
2020	14.4 MVA
2021	15.1 MVA
2022	15.5 MVA
2023	15.7 MVA
2024	16.1 MVA
2025	16.3 MVA
2026	16.7 MVA
2027	16.7 MVA
2028	16.8 MVA
2029	16.9 MVA

7.2. Location

The location where network support and load restoration capability will be measured / referenced is on the 33 kV bus at Planella substation; however alternative options may be located anywhere downstream, so long as they can be operationally utilised when required.

7.3. Timing

7.3.1. Implementation Timeframe

In order to ensure compliance with Ergon Energy's planning criteria and the National Electricity Rules, a non-network solution will need to be implemented by October 2023.

7.3.2. Time of Year

Load restoration capability (for Service Safety Net Targets) may be required at any time of the year, although required magnitude will be significantly lower during seasons with low to moderate daily peak loads, e.g. late autumn, winter and early spring.

7.3.3. Duration

Following a fault on the 33 kV line, the network support would be called upon for a duration of up to 48 hours. Specific timing will be agreed with providers as part of the contract negotiations.

Ergon Energy envisages that there may be in the order of 1 – 2 events per year where project proponents must supply the demand management reductions required.

7.4. Compliance with Regulations & Standards

As a distribution network service provider (DNSP), Ergon Energy must comply with regulations and standards, including the Queensland Electricity Act and Regulation, Distribution Authority, National Electricity Rules and applicable Australian Standards.

These obligations must be taken in consideration when choosing a suitable solution to address the identified need at Planella as discussed in this RIT-D report.

7.5. Longevity

Proposed non-network options will typically be required to provide solutions to the identified need for a period of at least 10 years. However, alternative solutions that can defer additional network investment for a smaller number of years may also be considered.

8. Feasible vs Non Feasible Options

8.1. Potentially Feasible Options

The identified need presented in this RIT-D report is driven by the capability and reliability of the existing 33 kV network that supplies Planella. As such, solutions that cost-effectively provide increased contingency load restoration capability are likely to represent reasonable options.

A non-exhaustive list of potentially feasible options includes:

- New embedded dispatchable network generation
- Existing customer generation
- Embedded energy storage systems.

8.2. Options that are Unlikely to be Feasible

Without attempting to limit a potential proponent's ability to innovate when considering opportunities, some technologies / approaches are unlikely to represent a technically or financially feasible solution.

A non-exhaustive list of options that are unlikely to be feasible includes:

- Renewable generation not coupled with energy storage and/or dispatchable generation
- Unproven, experimental or undemonstrated technologies.

9. Internal Options Identified

9.1. Non-Network Options Identified

Ergon Energy has not identified any viable non-network solutions internally that will address the identified need.

9.2. Distribution Network Options Identified

Ergon Energy's preferred internal option at this stage is to rebuild a 1.5 km section of the existing 33 kV NOMA-PLAN feeder that runs through the storm tide inundation flood zone using concrete pole construction, obtain easements and develop additional 11 kV feeder ties between Planella, North Mackay and Glenella substations in order to mitigate the Safety Net risks.

Upon completion of these works, Planella substation would be Safety Net compliant.

This option will minimise capital expenditure to cover load growth and Safety Net requirements, whilst also reducing expenditure on obsolete assets. It also allows Ergon Energy to alter the timing of future projects, notably the replacement of transformers at Planella and the conversion of Planella to 66/11 kV, to meet realised load growth.

Table 5: Ergon Energy's Internal Cost for the Preferred Option

Solution Description	Capital Cost (Excl. Ergon Overheads)	Commissioning Date
Ergon Energy Internal Option A (Preferred) Rebuild existing 33 kV feeder in flood zone with concrete poles, obtain easements & build 11 kV feeder ties	\$3.56M	2021/22

10. Submissions & Next Steps

10.1. Submissions from Solution Providers

Ergon Energy invites written submissions on this report from registered participants and interested parties.

With reference to Section 7, all submissions should include sufficient technical and financial information to enable Ergon Energy to undertake comparative analysis of the proposed solution against other options.

The proposals should include, but are not limited to:

- Full costs of completed works including delivery and installation where applicable
- Whole of life costs including operational costs
- Project execution strategy including design, testing and commissioning plans
- Engineering network system studies and study reports
- Verified and approved engineering designs if available

Ergon Energy will not be legally bound in any way or otherwise obligated to any person who may receive this RIT-D report or to any person who may submit a proposal. At no time will Ergon Energy be liable for any costs incurred by a proponent in the assessment of this RIT-D report, any site visits, obtainment of further information from Ergon Energy or the preparation by a proponent of a proposal to address the identified need specified in this RIT-D report.

Submissions in writing are due by **19 September 2019** and should be lodged to Ergon Energy's "Regulatory Investment Test for Distribution (RIT-D) Partner Portal" The portal is available at:

<https://www.ergon.com.au/network/network-management/network-infrastructure/regulatory-test-consultations>

10.2. Next Steps

Ergon Energy intends to carry out the following process to assess what action should be taken to address the identified need at Planella:

Step 1	Publish Non Network Options Report (this report) inviting non-network options from interested participants	Date Released: 24 June 2019
Step 2	Submissions in response to the Non Network Options Report	Due Date: 19 September 2019
Step 3	Review and analysis of proposals by Ergon Energy. This is likely to involve further consultation with proponents and additional data may be requested.	Anticipated to be completed by: 7 October 2019
Step 4	Release of the Draft Project Assessment Report (DPAR)	Anticipated to be released by: 14 October 2019
Step 5	Submissions in response to the Draft Project Assessment Report.	Due Date: 29 November 2019
Step 6	Review and analysis by Ergon Energy. This is likely to involve further consultation with proponents and additional data may be requested.	Anticipated to be completed by: 20 December 2019
Step 7	Release of Final Project Assessment Report (FPAR) including summary of submissions received	Anticipated to be released by: 23 December 2019
Ergon Energy reserves the right to revise this timetable at any time. The revised timetable will be made available on the Ergon Energy website.		

Ergon Energy will use its reasonable endeavours to maintain the consultation program listed above. However, due to changing power system conditions or other circumstances beyond the control of Ergon Energy this consultation schedule may change. Up-to-date information will be available on the Partner Portal.

During the consultation period, Ergon Energy will review, compare and analyse all internal and external solutions. At the conclusion of the consultation process, Ergon Energy will publish a final report which will detail the most feasible option. Ergon Energy will then proceed to take steps to progress the recommended solution to ensure any statutory non-compliance is addressed and undertake appropriately justified network reliability improvement, as necessary.