



Part of Energy Queensland

STNW3510

# Dynamic Standard for Small IES Connections

Effective from 23 February 2025

# Dynamic Standard for Small IES Connections



If this standard is a printed version, then the Energex or Ergon Energy Network internet site must be referenced to obtain the latest version to ensure compliance.

<b>Approver</b>	Carmelo Noel General Manager Asset Standards
If RPEQ sign off required insert details below.	
<b>Certified Person name and Position</b>	<b>Registration Number</b>
Han-Yang Chiu Senior Standards Engineer	18253

**Abstract:** This Standard has been prepared by Energex and Ergon Energy Network to provide Proponents of Dynamic Small IES with information about their rights and obligations in respect of connecting to, and interfacing with, the Energex or Ergon Energy Network Distribution Network. Energex and Ergon Energy Network as Queensland DNSPs have an inherent obligation to ensure that Small IES do not cause a material degradation in the quality of supply to other network users and do not adversely affect the operation of the Distribution Network.

**Keywords:** inverter, solar, connection, photovoltaic, wind, energy storage system, export, low voltage, LV, PV, Micro EG, Small ESS, Small IES, IES

## Table of Contents

1	Introduction.....	5
1.1	Purpose.....	5
1.2	Scope.....	5
1.3	Obligation of Proponents.....	6
2	Definitions and abbreviations.....	6
2.1	Definitions.....	6
2.2	Abbreviations.....	9
2.3	Terminology.....	10
2.3.1	Subcategories.....	10
3	Relevant rules, regulations, standards and codes.....	11
3.1	Standards and codes.....	11
3.1.1	Energex controlled documents.....	11
3.1.2	Ergon Energy Network controlled documents.....	11
3.1.3	Australian and New Zealand Standards.....	11
3.1.4	International Standards.....	12
3.2	Legislation and regulation.....	12
4	Technical requirements.....	14
4.1	Labelling and signage.....	14
4.2	Maximum system capacity.....	14
4.3	Generation Control.....	15
4.3.1	Export limits at Connection Point.....	15
4.3.2	Generation limit downstream of Connection Point.....	15
4.3.3	Import limits at Connection Point.....	16
4.3.4	Export and Import limit measurement and control.....	17
4.3.5	Phase Balance for Multiple-Phase Connections.....	18
4.3.6	Emergency Backstop Mechanism.....	19
4.4	Inverter Energy Systems.....	20
4.4.1	Energy Storage System (ESS).....	20
4.4.2	Electric Vehicles.....	21
4.4.3	Inverter Power Sharing Device (IPSD).....	21
4.5	Network connection and isolation.....	21
4.5.1	Changeover switches.....	22
4.6	Earthing.....	22
4.7	Protection.....	22
4.7.1	Inverter integrated protection.....	22

# Dynamic Standard for Small IES Connections

4.7.2	Interface Protection.....	22
4.8	Operating voltage and frequency.....	23
4.9	Metering .....	23
4.10	Power quality.....	23
4.10.1	IES power quality response modes.....	23
4.10.2	Disturbance issues.....	24
4.11	Communications systems.....	25
4.11.1	General.....	25
4.11.2	Connection of communication system.....	25
4.11.3	Information exchange .....	25
4.12	Data and information .....	25
4.12.1	Static data and information .....	25
4.12.2	Dynamic data and information .....	25
4.13	Cybersecurity .....	25
4.14	Technical studies.....	25
5	Fees and charges .....	26
6	Testing and commissioning.....	26
6.1	General .....	26
6.2	Commissioning of limits.....	26
6.3	Electromechanical meters .....	26
7	Operations and maintenance .....	27
7.1	General .....	27
7.2	Dynamic operation.....	27
	Appendix A: Deviations from the National DER Connection Guidelines (informative).....	28
	Appendix B: Connection arrangement requirements (normative) .....	29
	Appendix C: Model Standing Offer (informative) .....	30
	Appendix D: Static data and information (informative).....	31
	Appendix E: Dynamic data and information (informative) .....	32
	Appendix F: Compliance checklist (informative).....	33
	Appendix G: Small IES Dynamic EG Connection types (informative).....	35

## 1 Introduction

### 1.1 Purpose

The purpose of this Standard is to provide Proponents of Small IES Dynamic EG Connections up to 30 kVA information about their obligations in respect of connecting to, and interfacing with Energex or Ergon Energy Network's Distribution Network. This Standard has been developed to ensure safe and stable Parallel operation<sup>1</sup> of Small IES Units connected to the DNSP's network at the Premise.

### 1.2 Scope

This Standard applies to new connections and connection alterations of any Small IES with a total system capacity less than or equal to 30 kVA that is:

- intended to be connected to, and capable of operating in Parallel with the Distribution Network; and
- capable of responding to dynamic operating envelopes set by the DNSP.

This Standard does not apply to:

- electric vehicles, unless the Electric Vehicle Supply Equipment (EVSE) is capable of supplying electricity to the Distribution Network or electrical installation (in which case the requirements shall apply);
- DER systems that do not generate electricity, unless they impact on the ability of the Small IES to meet the technical requirements;
- back-up generation that does not operate in parallel with the Distribution Network; or
- EG Systems covered by the following Energex and Ergon Energy Network connection standards:

Standard Number	Title
STNW1170	Standard for Small IES Connections
STNW1174	Standard for LV EG Connections
STNW1175	Standard for HV EG Connections
STNW3511	Dynamic Standard for LV EG Connections
STNW3514	Standard for Small IES Connections to Isolated Networks
STNW3515	Standard for LV EG Connections to Isolated Networks

The technical requirements in this Standard comply with the framework of the National DER Connection Guidelines for Micro EG Connections as published by the Energy Networks Association (ENA).

---

<sup>1</sup> Section 225 of the *Electrical Safety Regulation 2013* requires that any person who has generating plant must comply with the entity's conditions for ensuring safe and stable parallel operation of the private generating plant with the works of the electricity entity.

# Dynamic Standard for Small IES Connections

## 1.3 Obligation of Proponents

Proponents shall:

- a. obtain the consent from the DNSP before interconnecting their Small IES Unit with the Distribution Network.
- b. ensure that the proposed Small IES Unit equipment and installation complies with the relevant Energy Laws, including any applicable standards, codes and guidelines.
- c. comply with this Standard and the terms and conditions of the negotiated connection contract.

Proponents shall not connect additional inverters, make modifications, or install additional Small IES Units, including Energy Storage Systems, without the prior written agreement of the DNSP.

## 2 Definitions and abbreviations

### 2.1 Definitions<sup>2</sup>

Term	Definition
Accredited Person	A person that is properly licensed under the relevant laws and holds accreditation from a peak industry body as competent to design and/or install renewable Generating Units and/or ESS. Accredited Persons may include accredited installers, designers and supervisors operating in accordance with the terms of their accreditation. To be eligible to produce Renewable Energy Certificates a SAA accredited person must be engaged.
Anti-islanding Protection	A protection system to detect islanded conditions and disconnect the inverter(s) from the Distribution System.
Break-before-make	Break-before-make operation is used in a switch that is configured to break (open) the first set of contacts before engaging (closing) the new contacts.
Connection Assets	Those components of a Distribution System which are used to provide connection services.
Connection Contract	A contract formed by the making and acceptance of a connection offer under Chapter 5A of the NER (or an offer to connect under Chapter 5, where the Proponent has made an election under rule 5A.A.2 of the NER), and includes contracts of the kind described under s67 of the NERL.
Connection Point	An agreed point of supply established between the DNSP's Distribution System and a Proponent's Premises.
Demand Response	The automated alteration of an inverter mode of operation in response to an initiating signal originating from or defined by the DNSP.
DER Technical Standards	Means the requirements for embedded generating units under Australian Standard AS4777.2:2020 as in force from time to time.
Disconnection Device	Device designed to safely prevent the flow of current such as circuit breaker or contactor.
Distribution Network	A network which is not a transmission network. This Standard refers to the Low Voltage or High Voltage portion of the DNSP's Distribution Network.
Distribution System	A distribution network, together with the connection assets associated with the distribution network, which is connected to another transmission system or distribution system. The relevant distribution system owned and operated by the DNSP to which the Small IES Unit(s) is, or will be, connected.

<sup>2</sup> Terms in italics and not otherwise defined in this document, have the meaning given to that term in the NER or National Energy Retail Law.

# Dynamic Standard for Small IES Connections

Term	Definition
Distribution Network Service Provider (or DNSP)	A person who engages in the activity of owning, controlling, or operating a distribution system. Depending on the context means either Energex (who owns and operates the Distribution System in South East Queensland) or Ergon Energy Network (who owns and operates the Distribution System in the remainder of Queensland).
Dynamic Small IES	EG Units of the kind contemplated by Australian Standard AS/NZS 4777 (Grid connection of energy systems via inverters) that have a nameplate rating of 30 kVA or less for which a Small IES Dynamic EG Connection is appropriate. Variation of some settings for the Dynamic Small IES, such as Import and Export, are supported through publishing of DOEs by the DNSP for the Connection Point.
Dynamic Operating Envelopes (or DOE(s))	Dynamic Operating Envelopes are where Dynamic Small IES setting limits, such as Import and Export limits, can vary over time and location
Embedded Generating System(s) (or EG System(s))	One or more embedded generating units and auxiliary equipment that are interconnected with the Distribution Network.
Embedded Generating Units(s) (or EG Units(s))	A generating unit connected within a Distribution System and not having direct access to the transmission network.
Emergency Backstop Mechanism	Involves the use of Generation Signalling Devices to provide a Demand Response that causes an IES to temporarily cease or reduce generation in emergency contingency events within the power system. The mechanism may be called upon to respond to a direction by AEMO issued in accordance with the NEL.
Energy Laws	Relevant laws relating to the subject matter of this Standard.
Energy Storage System (or ESS)	A system comprising one or more components (e.g. batteries) that store electricity generated by Distributed Energy Resources or directly from the grid, and that can discharge the electricity to loads.
Export	Net electricity that is fed from the Premises into the Distribution System through the Connection Point.
Generating Unit	The plant used in the production of electricity and all related equipment essential to its functioning as a single entity.
Generation	The production of electrical power by converting another form of energy in a Generating Unit.
Generation Limit	Function to limit the active power that can flow from an inverter or multiple inverters towards the rest of an electrical installation while meeting the requirements of AS/NZS 4777.2.
Generation Signalling Device (GSD)	A DRED providing functionalities and capabilities to achieve Demand Response, which satisfies the requirements of AS/NZS 4755.1 <sup>3</sup> .
High Voltage (or HV)	Any voltage greater than 1,000 V a.c. or 1,500V d.c.
Import	Net electricity that is supplied via the Distribution System through the Connection Point.
Interface Protection	Interface Protection is the protection contemplated by AS/NZS 4777 (grid connection of energy systems via inverters) installed to perform the functions of: coordinating multiple Inverter Energy System installations within the Premises, providing protection for the collective Inverter Energy System installation and islanding protection to the connected Distribution System as well as preserving safety of personnel and the general public.

<sup>3</sup> A list of Approved GSD can be found at Energex at: <https://www.energex.com.au/home/our-services/connections/low-voltage-generation/emergency-backstop-mechanism> and Ergon Energy Network at: <https://www.ergon.com.au/network/connections/low-voltage-generation/emergency-backstop-mechanism>

# Dynamic Standard for Small IES Connections

Term	Definition
Inverter Energy System (or IES)	A system comprising one or more inverters together with one or more energy sources (which may include an ESS) and controls, where the inverter(s) satisfies the requirements of AS/NZS 4777.2.
Inverter Power Sharing Device (IPSD)	Device used to share the generation from an inverter or multiple inverters to supply loads on Premises with multiple electrical installations.
Isolated Network	Refers to the small remote electricity Distribution Systems operated by Ergon Energy Network that are not connected to the national electricity grid and are supplied via a dedicated power station.
Low Voltage (or LV)	A voltage of no more than 1,000 V a.c. or 1,500 V d.c.
Negotiated Small IES Dynamic EG Connection	A connection between a Distribution System and a retail customer's Premises for a Small IES, for which a negotiated connection contract is in place.
Non-export	A Dynamic Small IES Unit that is capable of operating in Parallel with the Distribution Network and which is designed and configured to prevent any Export of electricity to the Distribution System across the Connection Point
Off-grid	A Small IES Unit which can supply a customer load as back-up, also known as "non-parallel". In this circumstance, the Small IES Unit(s) is not connected in Parallel and does not synchronise with the Distribution System. Loads shall be isolated from the Distribution Network when being supplied from the non-parallel Small IES Unit.
Parallel (or Grid Connected)	This is where the Small IES Unit is configured such that the Small IES Unit and the Distribution Network supply the installation simultaneously from time to time (even if this is a very short period of time). This includes circumstances where energy storage systems can be tied directly or indirectly back to the Distribution System through an AS/NZS 4777.2 grid connect inverter. It is irrelevant whether the Small IES Unit (including any ESS) Exports.
Partial-export	A Small IES that is capable of operating in Parallel with the Distribution Network and which is designed and configured to only Export as prescribed to operate in Section 4.3.1 of this Standard.
Power Limiting	The ability to reduce or stop power output from inverters when Export exceeds a defined value.
Premises	Means any land (whether a single block or multiple contiguous blocks), building(s) (whether whole or part), and structure(s) (or adjuncts thereto) that are owned, occupied or controlled by the Proponent in the vicinity of the proposed connection and which can reasonably be considered to be part of a single overarching operation.
Proponent	The retail customer that is the relevant owner, operator, or controller of the Small IES (or their agent).
Reactive Power	The rate at which reactive energy is transferred, which is a necessary part of an alternating current system containing inductive and capacitive components, as it regulates the voltage within the system. Reactive Power is measured in vars within the scope of this Standard.
Single Wire Earth Return (or SWER)	Parts of the electrical high voltage Distribution Network that use a single live conductor with the earth as the return current path. All Premises are supplied at LV either as single-phase or split-phase electric power.
Small IES Dynamic Embedded Generation Connection (or Small IES Dynamic EG Connection)	A connection between Dynamic Small IES and a distribution network.
Small IES Unit	A Generating Unit forming part of a Dynamic Small IES.
Split-phase SWER	A split-phase connection is a two-phase supply provided off a single SWER transformer.



# Dynamic Standard for Small IES Connections

Term	Definition
Standard	This document that is entitled “Dynamic Standard for Small IES Connections”.
Vehicle-to-Building (V2B)	Plug-in electric vehicle interaction with the Premises, including charging as well as discharging and bi-directional communication interface.
Vehicle-to-Grid (V2G)	Plug-in electric vehicle interaction with the electric grid, including charging as well as discharging and bi-directional communication interface.

## 2.2 Abbreviations

Term, abbreviation or acronym	Definition
AC or a.c.	Alternating current
ACR	Automatic Circuit Recloser
AEMO	Australian Energy Market Operator
AFLC	Audio Frequency Load Control
AS	Australian Standard
AS/NZS	A jointly developed Australian and New Zealand Standard
CEC	Clean Energy Council
CSIP	Common Smart Inverter Profile
CSIP-AUS	Common Smart Inverter Protocol Australia
DC or d.c.	Direct current
DER	Distributed Energy Resources
DOE	Dynamic Operating Envelope
DRED	Demand Response Enabling Device
EMC	Electromagnetic Compatibility
EV	Electric Vehicle
EVSE	Electric Vehicle Supply Equipment
GSD	Generation Signalling Device
IEC	International Electrotechnical Commission
IPSD	Inverter Power Sharing Device
MSO	Model Standing Offer
NEL	National Electricity Law
NER	National Electricity Rules
NERL	National Energy Retail Law
PV	Photovoltaic
QECM	Queensland Electricity Connection Manual
RPEQ	Registered Professional Engineer of Queensland
SAA	Solar Accreditation Australia
SEP2	IEEE 2030.5 <i>Standard for Smart Energy Profile Application Protocol</i>
SLD	Single Line Diagram
V2B	Vehicle-to-Building
V2G	Vehicle-to-Grid
VPP	Virtual Power Plant

# Dynamic Standard for Small IES Connections

## 2.3 Terminology

In this Standard:

- the word “shall” indicates a mandatory requirement that the Proponent must comply with;
- the word “should” indicates a recommended requirement that will not be mandatorily imposed on the Proponent; and
- the word “may” indicates a requirement that the DNSP may determine the Proponent must comply with.

### 2.3.1 Subcategories

The technical requirements set out in this Standard shall apply to the following subcategories of Small IES Dynamic EG Connections described in Table 1:

**Table 1 Subcategories**

Single-phase Small IES Dynamic EG Connection	Two-phase Small IES Dynamic EG Connection	Three-phase Small IES Dynamic EG Connection	Non-standard Small IES Dynamic EG Connection
System capacity ≤ 20 kVA <sup>1</sup>	System capacity ≤ 5 kVA PV & ≤ 5 kVA ESS per phase, up to 10 kVA PV & 10 kVA ESS <sup>1</sup>	System capacity ≤ 10 kVA per phase, up to 30 kVA <sup>1</sup>	Aggregate system capacity ≤ 30 kVA <sup>1</sup> : <ul style="list-style-type: none"> <li>• SWER network; or</li> <li>• Premises with more than one LV Connection Point</li> <li>• Connections utilising IPSD</li> </ul>

Note 1: Export limits apply for each subcategory and are as set out in Table 3 of this Standard.

The following connections are considered to be non-standard for this Standard:

- Premises connected (or connecting) to SWER networks, that have technical constraints which limits the capacity of Small IES Units to be connected to LV networks with upstream SWER networks in comparison to the standard urban and rural networks.
- Premises connected (or connecting) to the Distribution System at more than one LV Connection Point.
- Premises connected (or connecting) to the Distribution System utilising IPSD.

Further details regarding the categories of Small IES that are capable of being connected under the DNSP Standards are set out in Appendix G: Small IES Dynamic EG Connection Types.

If further clarification is required to determine which subcategory applies to a Proponent, please contact

For Ergon Energy Network – [ergongeneration@energyq.com.au](mailto:ergongeneration@energyq.com.au)  
For Energenx – [energenxgeneration@energyq.com.au](mailto:energenxgeneration@energyq.com.au)

## 3 Relevant rules, regulations, standards and codes

### 3.1 Standards and codes

There are a range of applicable standards and industry codes which define connection types and applicable requirements, as set out below.

In the event of any inconsistency between:

- an applicable Australian and international standards and industry codes (except for legislated industry codes where compliance is mandated by law); and
- this Standard,

this Standard will prevail.

#### 3.1.1 Energex controlled documents

A copy of the latest version of this Standard may be obtained by searching for STNW3510 from the following website: <https://www.energex.com.au/>

Other controlled documents include:

Document number	Document name	Document type
Manual 01811	Queensland Electricity Connection Manual	Reference
STNW1170	Standard for Small IES Connections	Standard
STNW1174	Standard for LV EG Connections	Standard
STNW1175	Standard for HV EG Connections	Standard
STNW3511	Dynamic Standard for LV EG Connections	Standard

#### 3.1.2 Ergon Energy Network controlled documents

A copy of the latest version of this Standard may be obtained by searching for STNW3510 from the following website: <https://www.ergon.com.au/>

Other controlled documents include:

Document number	Document name	Document type
2912908	Queensland Electricity Connection Manual	Reference
STNW1170	Standard for Small IES Connections	Standard
STNW1174	Standard for LV EG Connections	Standard
STNW1175	Standard for HV EG Connections	Standard
STNW3511	Dynamic Standard for LV EG Connections	Standard
STNW3514	Standard for Small IES Connection on Isolated Networks	Standard
STNW3515	Standard for LVEG Connections to Isolated Networks	Standard

#### 3.1.3 Australian and New Zealand Standards

Document number	Document name	Document type
AS/NZS 3000	Electrical Installations – Wiring Rules	AU/NZ Joint Standard

# Dynamic Standard for Small IES Connections

AS/NZS 4755.1	Demand response capabilities and supporting technologies for electrical products – Part 1: Demand response framework and requirements for demand response enabling devices (DREDs)	AU/NZ Joint Standard
AS/NZS 4777	Grid connection of energy systems via inverters, (multiple parts)	AU/NZ Joint Standard
AS/NZS 5033	Installation and Safety Requirements for Photovoltaic (PV) Arrays	AU/NZ Joint Standard
AS/NZS 5139	Electrical Installations - Safety of battery systems for use with power conversion equipment	AU/NZ Joint Standard
AS/NZS 61000.4.30	Electromagnetic compatibility (EMC) – Part 4.30: Testing and measurement techniques - Power quality measurement methods	AU/NZ Joint Standard
SA/SNZ TR IEC 61000.3.14	Electromagnetic compatibility (EMC) – Part 3.14: Limits - Assessment of emission limits for harmonics, interharmonics, voltage fluctuations and unbalance for the connection of disturbing installations to LV power systems	AU/NZ Joint Standard
AS 62040.1	Uninterruptible power systems (UPS)	Australian Standards
AS/NZS IEC 62116	Utility-interconnected photovoltaic inverters – Test procedure of islanding prevention measures	Australian Standard
SA HB 218:2023 (or CSIP-AUS)	Common Smart Inverter Profile — Australia with Test Procedures	Australian Standard Handbook

## 3.1.4 International Standards

Document number	Document name	Document type
CSIP	IEEE 2030.5 Common California IOU Rule 21 Implementation Guide for Smart Inverters	International Standard
IEEE 2030.5 (or SEP2)	2030.5-2018 - IEEE Standard for Smart Energy Profile Application Protocol	International Standard

## 3.2 Legislation and regulation

Set out below is a list of the applicable legislation and regulations (which may be amended, replaced, repealed or have further instruments enacted from time to time).

In the event of any inconsistency between:

- any applicable legislation and regulation; and
- this Standard,

the legislation and regulations will prevail.

# Dynamic Standard for Small IES Connections

Document name	Document type
DER Technical Standard	Regulation
Electricity Act 1994 (Qld)	Legislation
Electricity Regulation 2006 (Qld)	Regulation
Electrical Safety Act 2002 (Qld)	Legislation
Electrical Safety Regulation 2013 (Qld)	Regulation
Electricity - National Scheme (Queensland) Act 1997 (Qld)	Legislation
National Electricity (Queensland) Law, as defined in the Electricity - National Scheme (Queensland) Act 1997 (Qld)	Regulation
National Energy Retail Law (Queensland) Act 2014 (Qld)	Legislation
National Energy Retail Law (Queensland), as defined in the National Energy Retail Law (Queensland) Act 2014 (Qld)	Regulation
National Electricity Rules	Regulation
Professional Engineers Act 2002 (Qld)	Legislation

## 4 Technical requirements

### 4.1 Labelling and signage

Labels and signs on the Dynamic Small IES, including cables, shall meet the requirements of AS/NZS 4777.1, AS/NZS 3000, AS/NZS 5033 and AS/NZS 5139.

### 4.2 Maximum system capacity

The maximum aggregate system capacity for Small IES Dynamic EG Connections covered under this Standard shall meet the requirements in Table 2. For single-phase connections with an aggregate capacity > 10 kVA, the maximum capacity allocation is split into allocations for solar PV and ESS.

**Table 2 Small IES Dynamic EG Connection maximum system capacity**

		Enabled for Dynamic Operation <sup>1</sup>
Single-phase		≤ 10 kVA PV & ≤ 10 kVA ESS <sup>2</sup>
Two-phase		≤ 5 kVA PV & ≤ 5 kVA ESS per phase <sup>3</sup>
Three-phase		≤ 10 kVA per phase <sup>3</sup>
SWER	Single-phase	≤ 15 kVA PV & ≤ 15 kVA ESS <sup>2</sup>
	Split-phase	≤ 5 kVA PV & ≤ 5 kVA ESS per phase <sup>3</sup>

Note 1: A Dynamic Small IES is enabled for dynamic operation where it meets the requirements of Table 13 in Section 7.2.

Note 2: For maximum capacity with separate allocation limits for PV and ESS:

- the maximum capacity for PV is calculated based on the total IES with connected solar PV; and
- the maximum capacity for Energy Storage Systems (ESS) includes the total IES with connected ESS, including batteries and electric vehicles as per Sections 4.4.1 and 4.4.2.

Note 3: Multiple-phase EG Systems shall meet phase balance requirements from Section 4.3.5 of this Standard.

Where there are multiple EG Systems at a Premises connected via a single Connection Point, the system capacity will consider the aggregate of the existing and proposed EG System.

For Premises with multiple LV Connection Points, Premises with network(s) connected to multiple Connection Points, or EG system(s) being connected to multiple Connection Points, the standard shall be applied to meet the following:

- The maximum capacity is the aggregate of all EG units connected or proposed for connection to all LV Connection Points, on the Premise and for all connected network(s).
- All criteria in this Standard and the Technical Study will be applied for the aggregate maximum capacity.

This section shall be applied with consideration to the entire Standard. Proponents with a multiple-phase connection shall meet the phase balance requirements of Section 4.3.5 of this Standard.

# Dynamic Standard for Small IES Connections

This Standard can only be applied up to a total aggregate capacity of 30 kVA. System capacity for a bulk metered Premises, such as strata title (e.g. retirement villages) are aggregated at the Connection Point. The Proponent is responsible for compliance with the requirements set out in this Standard, including, but not limited to, phase balancing.

## 4.3 Generation Control

### 4.3.1 Export limits at Connection Point

The Export limits for a Dynamic Small IES shall meet the following requirements:

- a. The dynamic Export limits are communicated by the DNSP to the Dynamic Small IES, which will be no less than the minimum and no more than the maximum shown in Table 3.
- b. Any time that the communication system (described in Section 4.11 of this Standard) is not fully operational (including, but not limited to, a loss of signal, the Dynamic Small IES not receiving or not being able to respond to the dynamic Export limit), the permitted Export shall be limited to the 'Fixed Default Dynamic Export Limit' as set out in Table 3. This Export limit will apply at the Connection Point to the combined EG within the Premises (including any EG Units that may have been previously connected under different connection arrangements).
- c. For Premises with multiple Connection Points, the Export limit is the total for the Premises and the aggregate Export across the Connection Points must stay within the Export limits set out in Table 3.
- d. The Export limits shall meet the measurement and control requirements in Section 4.3.4.

**Table 3 Dynamic Export limits**

Subcategory	Fixed Default Dynamic Export limit	Maximum Dynamic Export limit	Technical Study Required
All	1.5 kW	10 kW per phase <sup>1,2,3</sup>	No

Note 1: Multiphase EG Systems shall meet phase balance requirements from Section 4.3.5 of this Standard.

Note 2: Availability of Export limits greater than the 'Fixed Default Dynamic Export limit' set out in Table 3, are subject to capacity availability of the Distribution Network System.

Note 3: Aggregate Export limits will not be permitted to exceed Distribution System capacity limits.

The ability of the Dynamic Small IES to Export into the Distribution System will be subject to the characteristics of the Distribution System from time to time, and the DNSP is unable to, and does not, represent, warrant or guarantee that the Dynamic Small IES will be able to Export electricity into the Distribution System at any time. Circumstances which may cause the Export to be constrained include but are not limited to when power quality response modes are in operation.

### 4.3.2 Generation limit downstream of Connection Point

For Premises with a multiple-phase connection to the network, Generation Limit control as specified in AS/NZS 4777.2 may be applied to control the active power output levels of EG(s) as per Table 4. Where Generation Limit has been applied, the Generation Limit shall be substituted for the EG's nameplate rating.

# Dynamic Standard for Small IES Connections

**Table 4 Generation Limit Categories**

Category	Generation Limit	Single-Phase Inverter Maximum Nameplate Rating
V2G	5 kW per phase <sup>1</sup>	8 kVA per phase
V2B	5 kW per phase <sup>1</sup>	8 kVA per phase

Note 1: Generation Limits may need to be reduced to meet system capacity and phase balance requirements in this Standard.

## 4.3.3 Import limits at Connection Point

Dynamic Small IES capable of importing electricity from the Distribution Network, such as an ESS, shall be subject to Import limits. The Import limits for a Dynamic Small IES shall meet the following requirements:

- The dynamic Import limits are communicated by the DNSP to the Dynamic Small IES, which will be no less than the minimum and no more than the maximum shown in Table 5.
- Any time that the communication system (described in Section 4.11 of this Standard) is not fully operational (including, but not limited to, a loss of signal, the Dynamic Small IES not receiving or not being able to respond to the dynamic Import limit), the permitted Import shall be limited to the 'Fixed Default Dynamic Import Limit' as set out in Table 5.
- For Premises with multiple Connection Points, the Import limit is the total for the Premises and the aggregate Import across the Connection Points must stay within the Import limits set out in Table 5
- The Import limits shall meet the measurement and control requirements in Section 4.3.4.

**Table 5 Dynamic Import limits**

Subcategory		Fixed Default Dynamic Import limit	Maximum Dynamic Import limit	Technical study required
Single-phase		1.5 kW	18 kW	No
Two-phase		1.5 kW	10 kW per phase <sup>1,2,3</sup>	No
Three-phase		1.5 kW	10 kW per phase <sup>1,2,3</sup>	No
SWER	Single-phase	1.5 kW	10 kW	Yes
	Split-phase	1.5 kW	10 kW per phase <sup>1,2,3</sup>	Yes

Note 1: Multiple-phase EG Systems shall meet phase balance requirements from Section 4.3.5 of this Standard.

Note 2: Availability of Import limits greater than the 'Fixed Default Dynamic Import limit' set out in Table 5 are subject to capacity availability of the Distribution System.

Note 3: Aggregate Import limits will not be permitted to exceed Distribution System capacity limits.

The Proponent shall not exceed the maximum supply limits in the QECM or the limits within the Connection Contract for supply.



# Dynamic Standard for Small IES Connections

## 4.3.4 Export and Import limit measurement and control

### 4.3.4.1 General

The total aggregate Export or Import of all the inverters at the Connection Point shall not exceed the approved limits.

For Premises with multiple LV Connection Points, Premises with network(s) connected to multiple Connection Points, or EGsystem(s) being connected (directly or indirectly) to multiple Connection Points, the standard shall be applied to meet the following:

- a. the minimum and maximum Export and Import limits are applied to the Premises and the Connection Points must collectively achieve these limits;
- b. in addition to the maximum Export and Import limits, a Proponent may be required to design the EG system to meet Export or Import limits applied to an individual Connection Point. No Export or Import limit for an individual Connection Point shall exceed the maximum Export and Import limit for the Premise;
- c. all criteria in this Standard and the Technical Study will be applied for the Premises and the Connection Points collectively.
- d. Import and Export limits cannot be set to be exceeded by another entity (such as a VPP or mobile application).

### 4.3.4.2 Measurement of Export and Import limits

The reference point for the measurement of Export and Import limits shall be:

- a. Measured at a point as close to the Connection Point as practicable, referencing a single point beyond the Connection Point within the Premises.
- b. Connected at a location that has a lower impedance to the Connection Point than any EG Unit connected within the Premises.

### 4.3.4.3 Measurement device compliance

The instrument transformers used to interface the equipment used to manage Export and Import limits for the Premises shall have certified compliance with:

- a. AS 61869.1 General requirements
- b. AS 61869.2 Additional requirements for current transformers;
- c. AS 61869.3 Additional requirements for inductive voltage transformers; and
- d. AS 61869.4 Additional requirements for combined transformers

### 4.3.4.4 Control of Export and Import limit

Export limits for Fixed IES EG shall be interpreted as “soft”, respond within 15 s, and meet the requirements of soft Export limits in Clause 3.4.8 of AS/NZS 4777.1.

Export limits shall be set to meet Table 6.

**Table 6 Export limit settings**

	Non-export	Partial-export
Export limit setting (kW)	0	$k$ of total inverter rating

Note 1: Where  $k$  is equal to the approved Partial-export power value as a per unit value of the inverter capacity. For example, where the approved Partial-export value is 2.5 kW of a 5 kVA inverter,  $k = 0.5$  (or 50%).

The control function for Import limitation shall meet the following requirements:

- a. have a limit that will cause the Dynamic Small IES to reduce its consumption, preventing Import at the Connection Point greater than the Import limit;
- b. where the Import limit is exceeded, the Import control function shall operate to ensure the Dynamic Small IES meets the import conditions within 15 seconds;
- c. the Import control device settings shall be secured against inadvertent or unauthorized tampering. Changes to settings shall require the use of a tool and special instructions not provided to unauthorized personnel.

Where the Export (or Import) control function loses connection with an external device, or detects any fault or loss of operation of the Export (or Import) control function, it shall reduce Export (or Import) to the fixed Export limit (or fixed Import limit respectively).

The Import limit shall apply to all of the EG Units connected within the Premises. Total Import at the Connection Point to the electrical installation will remain within the limits described in the customer connection contract.

The control of the Small IES for Export or Import limitation shall not interfere with Anti-islanding Protection of the inverter(s).

The ability of the EG System to Export into and Import from the Distribution System at the limits described in Table 3 and Table 5 will be subject to the characteristics of the Distribution System from time to time, and the DNSP is unable to, and does not, represent, warrant or guarantee that the EG System will be able to Export/Import at any time. Circumstances which may affect the Export or Import to be constrained include but are not limited to when power quality response modes are in operation.

## 4.3.5 Phase Balance for Multiple-Phase Connections

For all multiple-phase connections to the network, the phase balance requirements in AS/NZS 4777.1 Appendix C applies including:

- a. Customers that may have a combination of single-phase and/or three-phase inverters in compliance with AS/NZS 4777.2.
- b. All multiple-phase IES Units shall have a balanced a.c. output.
- c. Where single-phase inverters are installed for both PV and ESS they shall be installed on the same phase.
- d. For IES with an aggregate rating  $\leq 30$  kVA the additional phase balance requirements in Section 4.3.5.1 of the Standard apply.

### 4.3.5.1 Phase Balance for Connections with IES 30 kVA and under

For multiple-phase connections where the aggregate IES nameplate rating for singlephase and balanced three-phase inverters are  $\leq 30$  kVA, the limits in Table 7 shall be met:

**Table 7 Phase Balance Requirements for Multiple-Phase Connections with IES ≤ 30 kVA**

Multiple-Phase Connections with IES ≤ 30 kVA	Single-Phase Inverter Aggregate Nameplate Rating Limit	Balance Three-Phase Inverter Aggregate Nameplate Rating Limit
PV Inverters	5 kVA per phase	30 kVA
ESS Inverters	5 kVA per phase	30 kVA
V2G or V2B Inverters <sup>1</sup>		
Aggregate of Combined IES	10 kVA per phase	30 kVA

Note 1: Generation Limit may be applied to V2G or V2B single-phase inverter as per Section 4.3.2 of this Standard to meet phase balance requirements.

Where there is a combination of single-phase inverters, the maximum nameplate rating imbalance of all IES shall not exceed 5 kVA between phases.

## 4.3.6 Emergency Backstop Mechanism

### 4.3.6.1 Application

Negotiated Small IES Dynamic EG Connections that satisfy the following conditions shall comply with Section 4.3.6.2 of this Standard to enable the Emergency Backstop Mechanism:

- a. the aggregated system capacity of all inverters<sup>4</sup> at the Premises is equal to or above 10 kVA; and
- b. the Distribution System has AFLC service available at the Connection Point<sup>5</sup>.

### 4.3.6.2 Configuration for an Emergency Backstop Mechanism

Subject to Section 4.3.6.1 of this Standard, a Proponent shall ensure that any Negotiated Small IES Dynamic EG Connection is configured to comply with the following requirements:

- a. installation of aGSD in accordance with the QECM Drawings Supplement<sup>6</sup> for all inverters that:
  1. are, or were, installed or altered pursuant to a Connection Contract dated on or from 6 February 2023; and
  2. are not connected exclusively with an ESS DC source;
- b. the inverter is configured to enable functionality of the demand response mode DRM 0 in compliance with AS/NZS 4777.2.

<sup>4</sup> Including inverters with ESS DC sources.

<sup>5</sup> AFLC service availability can be checked for Energex at: <https://www.energex.com.au/home/our-services/connections/low-voltage-generation/emergency-backstop-mechanism> and Ergon Energy Network at: <https://www.ergon.com.au/network/connections/low-voltage-generation/emergency-backstop-mechanism>

<sup>6</sup> [https://www.energex.com.au/\\_data/assets/pdf\\_file/0003/1170993/Queensland-Electricity-Connection-Manual-Drawings-Supplement-Version-4-15919201.pdf](https://www.energex.com.au/_data/assets/pdf_file/0003/1170993/Queensland-Electricity-Connection-Manual-Drawings-Supplement-Version-4-15919201.pdf) or [https://www.ergon.com.au/\\_data/assets/pdf\\_file/0003/1170993/Queensland-Electricity-Connection-Manual-Drawings-Supplement-Version-4-15919201.pdf](https://www.ergon.com.au/_data/assets/pdf_file/0003/1170993/Queensland-Electricity-Connection-Manual-Drawings-Supplement-Version-4-15919201.pdf)

- c. where the inverter does not have an integrated device for the demand response mode, an external device is installed in accordance with Clause 3.2.1 of AS/NZS 4777.2.

## 4.4 Inverter Energy Systems

The following requirements apply to IES that are comprised of Dynamic Small IES inverters:

- a. inverters shall be tested and certified by an authorised testing laboratory as being compliant with AS/NZS 4777.2 (with an accreditation number issued).
- b. the inverters shall be registered with CEC as approved grid connect inverters.
- c. the inverters shall be tested and certified by an authorised testing laboratory as being compliant with AS/NZS IEC 62116 for active Anti-islanding Protection.
- d. the inverters shall be installed in compliance with AS/NZS 4777.1.
- e. the inverters shall have both volt-var and volt-watt response modes available and be capable of operating the modes concurrently, as per Section 4.10.1 of this Standard.
- f. the inverters shall be set to the regional setting "Australia A".
- g. inverters shall be capable of sending and receiving information via SEP2 using CSIP-AUS directly or via a third party.

### 4.4.1 Energy Storage System (ESS)

The connection of an ESS (such as batteries or EV and EVSE) capable of supplying electricity to an electrical installation such as the Premises or the Distribution System is considered Grid Connected, unless the inverter is connected behind a Break-before-make switch in accordance with Section 4.5.1 of this Standard or is an UPS in accordance with AS 62040.1.

Where the ESS is considered to be Grid Connected:

- a. the ESS shall be subject to the requirements of this Standard.
- b. the inverters for the ESS shall be installed in accordance with Section 4.4 of this Standard;
- c. the installation of battery ESS shall comply with AS/NZS 5139.
- d. the ESS is either externally DC coupled to an inverter or packaged as a product into an integrated system with an inverter and AC-coupled. The following requirements shall apply to ESS inverters:
  - 1. the inverter capacity for any ESS inverter will be included in the aggregated nameplate rating<sup>7</sup> of inverters at the Connection Point.
  - 2. the Export limit for the ESS inverter will be considered as part of the aggregated Export limit at the Connection Point.

The installation and commissioning of an ESS shall be certified as compliant by an Accredited Person.

---

<sup>7</sup> Nameplate rating for any inverter shall be based on the maximum continuous rating of the inverter throughout this Standard

## 4.4.2 Electric Vehicles

EVSE that is only capable of charging from the grid are not considered a Small IES Unit but rather a load and are subject to the requirements outlined in Clause 8.14.2.2 of the QECM.

EVSE shall be considered an ESS, and is subject to the requirements set out in Clause 8.16.2 of the QECM and Section 4.4.1 of this Standard, where:

- a. the EVSE is capable of supplying electricity into the Premises but not the Distribution System, resulting in a Non-export configuration (also referred to as Vehicle-to-Building or V2B); or
- b. the EVSE is capable of supplying electricity into the Premises and exporting into the Distribution System, resulting in either a full- or Partial-export configuration (also referred to as Vehicle-to-Grid or V2G); or
- c. the EVSE being installed has the capability to supply electricity into either the Premises or the Distribution System.

Where an EVSE is an ESS, its nameplate rating shall be counted towards the ESS inverter capacity for the purposes of determining maximum system capacity as per Section 4.2 of this Standard.

Note: EVSE capable of supplying electricity into the Premises or Distribution System is a type of energy storage system; they are not categorised as a battery system that conforms to AS/NZS 5139

## 4.4.3 Inverter Power Sharing Device (IPSD)

The following requirements apply for the use of IPSD on Premises with multiple electrical installations:

- a. The IPSD shall not interfere with the safety, functional and performance requirements for an IES conforming with AS/NZS 4777.2.
- b. IPSD shall be installed in compliance with AS/NZS 4777.1.
- c. The design and implementation of the IPSD installation shall be completed under engineering supervision by an RPEQ.

## 4.5 Network connection and isolation

Requirements for connecting to the Distribution System, including any isolation requirements, shall be in accordance with AS/NZS 4777.1 and AS/NZS 3010.

In addition, the following conditions shall apply:

- a. mechanical isolation shall be in accordance with AS/NZS 3000 including that the isolator must always be readily accessible;
- b. any means of isolation (where lockable) shall be able to be locked in the open position only.

# Dynamic Standard for Small IES Connections

## 4.5.1 Changeover switches

Any Small IES Unit connected behind a Break-before-make switch, that is, it isolates the changeover circuit when transferring between a Grid Connected supply to Generation supply, will be considered as an Off-grid inverter.

The following shall be considered as Grid Connected Small IES Units and will be required to comply with the requirements of this Standard:

- a. a Small IES Unit connected behind a Make-before-break switch that results in a momentary, or longer, connection between grid supply and Generation supply circuits when performing a changeover.
- b. a multiple mode inverter with uninterruptible power supply (UPS) mode functionality that is Grid Connected but also supplies an Off-grid circuit.

## 4.6 Earthing

The earthing requirements shall include:

- a. for IES and EV or EVSE capable of supplying energy, earthing requirements shall be as per AS/NZS 4777.1 and AS/NZS 3000;
- b. for battery ESS, earthing requirements shall be as per AS/NZS 5139 and AS/NZS 3000.

## 4.7 Protection

### 4.7.1 Inverter integrated protection

The inverter integrated protection requirements for inverters connected to the Distribution System shall comply with AS/NZS 4777.1 and AS/NZS 4777.2.

Active Anti-islanding Protection requirements shall apply as per AS/NZS 4777.2.

Inverters shall be set to the values given in Table 8 of this Standard, which is consistent with the passive Anti-islanding Protection requirements in Table 4.1 and Table 4.2 from AS/NZS 4777.2.

**Table 8 Prescribed Inverter Settings**

Parameter	Settings	Trip delay time	Maximum disconnection time
Undervoltage 2 (V<<)	70 V	1 s	2 s
Undervoltage 1 (V<)	180 V	10 s	11 s
Overvoltage 1 (V>)	265 V	1 s	2 s
Overvoltage 2 (V>>)	275 V	—	0.2 s
Under-frequency (F<)	47 Hz	1 s	2 s
Over-frequency (F>)	52 Hz	—	0.2 s
Reconnect time	60 s	N/A	N/A

### 4.7.2 Interface Protection

This section has been left intentionally blank.

# Dynamic Standard for Small IES Connections

## 4.8 Operating voltage and frequency

The proposed installation shall be able to operate within the limits of supply voltage:

$$V_{\text{phase-to-neutral}} = 230V \pm 10\%.$$

The maximum sustained voltage set point for IES Dynamic EG Systems,  $V_{\text{nom\_max}}$  as per AS/NZS 4777.2, shall be set at 258V.

The proposed Small IES Unit installation shall not cause more than 2% voltage rise at the Connection Point. Voltage rise is calculated from the a.c. terminals of the inverter or inverters to the Connection Point using a method contained in Clause 3.3.3 of AS/NZS 4777.1.

## 4.9 Metering

This section has been left intentionally blank.

## 4.10 Power quality

### 4.10.1 IES power quality response modes

The volt-var and volt-watt response modes specified in Clause 3.3.2.2 and Clause 3.3.2.3 of AS/NZS 4777.2 shall both be enabled as per below Table 9 and Table 10 for IES. For IES with energy storage the volt-watt response mode when charging, specified in Clause 3.4.3 of AS/NZS 4777.2 shall be enabled as per Table 11.

**Table 9 Volt-var response mode settings**

Reference	Voltage	Inverter reactive power level (Q) % of $S_{\text{rated}}$
$V_{V1}$	207 V	44% supplying <sup>1</sup>
$V_{V2}$	220 V	0%
$V_{V3}$	240 V	0%
$V_{V4}$	258 V	60% absorbing <sup>1</sup>

Note 1: Absorbing is when the Small IES Unit absorbs reactive power from the Distribution System and supplying is when the Small IES Unit acts as a source of reactive power into the Distribution System.

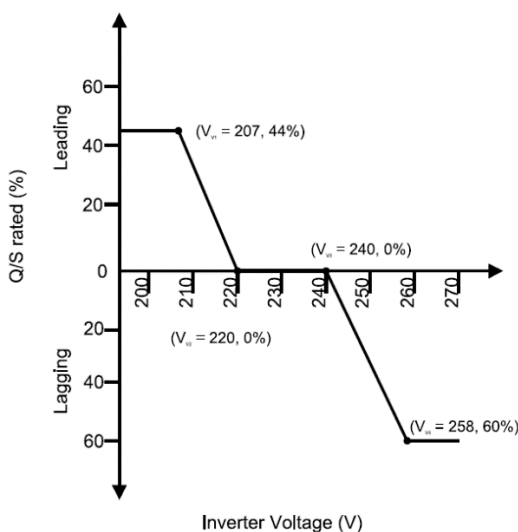

**Figure 1 Volt-var response mode**

# Dynamic Standard for Small IES Connections

**Table 10 Volt-watt response mode settings**

Reference	Voltage	Inverter maximum active power output level (P) % of $S_{rated}$
V <sub>w1</sub>	253 V	100%
V <sub>w2</sub>	260 V	20%

Note 1: Where P is the output power of the inverter and  $P_{rated}$  is the rated output power of the inverter

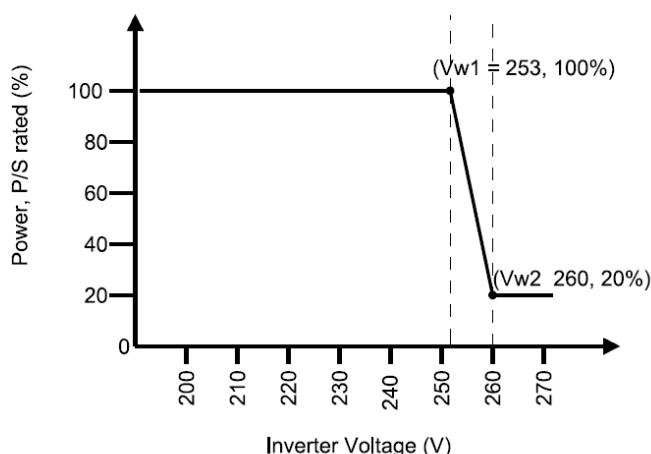

**Figure 2: Volt-watt response mode**

**Table 11 Volt-watt response mode settings for inverters with energy storage when charging**

Reference	Voltage	Power Input, $P_{charge}/P_{rated-ch}$ (%)
V <sub>w1-ch</sub>	207 V	20%
V <sub>w2-ch</sub>	215 V	100%

Power quality response modes shall commence and complete in accordance with their defined characteristics in Clause 3.3.2 and 3.4.3 in AS/NZS 4777.2 within the relevant times specified in Table 12 below:

**Table 12 Maximum response time for power quality response modes**

Response commencement time	Response completion time
1 s	10 s

## 4.10.2 Disturbance issues

Disturbance to the LV network shall be assessed against SA/SNZ TR IEC 61000.3.14.

Measurement of voltage disturbances shall be as described in AS/NZS 61000.4.30 using Class A instruments.



# Dynamic Standard for Small IES Connections

## 4.11 Communications systems

### 4.11.1 General

A Dynamic Small IES shall support the sending and receiving of information to the DNSP with communication systems that meets the following requirements:

- a. connection of the Dynamic Small IES to the public internet; and
- b. compliance with SEP2 using CSIP-AUS.

### 4.11.2 Connection of communication system

The communication systems for a Dynamic Small IES shall be met by one of the following methods of connection for information exchange via SEP2 using CSIP-AUS:

- a. direct connection of an EG Unit; or
- b. third-party device which communicates with the EG Unit(s); or
- c. cloud based vendor which communicates with the EG Unit(s).

For installations with multiple EG Units for which the communication systems cannot support communication with all of the installed EG Units, EG Unit(s) installed prior to 23 February 2025 that cannot be communicated must be set to non-export and non-import. If an inverter installed prior to 23 February 2025 is replaced or altered, the replaced or altered inverter must be capable of information exchange via SEP2 using CSIP-AUS.

### 4.11.3 Information exchange

The communications system shall be able to support sending and receiving information with the following frequency and capacity:

- a. frequency of no less than 5 minutes; or
- b. forecast information shall be provided for upto 24 hours, with the supply of 5-minute forecasts for the next immediate hour and 1 hourly forecasts for the next 23 hours.

## 4.12 Data and information

### 4.12.1 Static data and information

Static data and information shall be provided by the Proponent to the DNSP as per Appendix D.

### 4.12.2 Dynamic data and information

Dynamic data and information that is required to be provided by the Proponent to the DNSP as per Appendix E.

## 4.13 Cybersecurity

This section has been left intentionally blank.

## 4.14 Technical studies

Negotiated Small IES Dynamic EG Connections covered by this Standard may be required to undertake technical studies.

## 5 Fees and charges

Information regarding fees and charges applicable to Proponents is available at the following links:

Energex: <https://www.energex.com.au/our-services/connections/residential-and-commercial-connections/connection-charges>

Ergon Energy Network: <https://www.ergon.com.au/network/connections/residential-connections/connection-services-charges>

## 6 Testing and commissioning

### 6.1 General

On-site testing and commissioning shall be undertaken in accordance with AS/NZS 4777.1, AS/NZS 3000, AS/NZS 5139 and AS/NZS 5033 (where applicable), the equipment manufacturer's specifications, and the DNSP's technical requirements to demonstrate that the Dynamic Small IES meets the requirements of the applicable customer connection contract. The tests shall be installation tests, not type tests.

Commissioning tests for the inverter shall be in accordance with AS/NZS 4777, including:

- a. operate the main switch (inverter) and verify the connection time is greater than 60 seconds;
- b. isolate the main switch (grid) and verify the disconnect time is less than 2 seconds;
- c. where Export Limiting Operation is required, disconnect Proponent's load and confirm Export to the grid does not exceed the approved limits.
- d. where Emergency Backstop Mechanism is required, the inverter is configured to interact with the GSD.

### 6.2 Commissioning of limits

A Dynamic Small IES shall be commissioned with fixed Default Import and Export limits. Import and Export limits shall not be set above the fixed Default Import and Export limits by an installer or the Proponent. Refer to Table 3 and Table 5.

To support Dynamic Limits being issued to the Dynamic Small IES by the DNSP:

- a. the Dynamic Small IES shall be connected to the internet; and
- b. Registration for the Premises with the DNSP, via the Registration System shall be completed by the Proponent.

### 6.3 Electromechanical meters

If the meter at the Premises is an electromechanical meter, the Proponent shall ensure that the Small IES Unit shall be left with DC isolators on and AC isolators off until the Proponent's electricity retailer has confirmed that the metering equipment at the Premises has been modified or reconfigured to comply with the Energy Laws. For all new connections and connection alterations, the Accredited Person shall ensure compliance of the IES and complete the compliance checklist in Appendix F, and a copy of this checklist shall be left on site for the DNSP's connection officers.

## 7 Operations and maintenance

### 7.1 General

Dynamic Small IESs shall be operated and maintained by the Proponent, to ensure compliance with their customer connection contract and all legislation, codes, and/or other regulatory requirements at all times.

The Proponent shall ensure that the Dynamic Small IES and other systems and facilities at the Premises operate satisfactorily:

- a. for the full range of variation of system parameters and characteristics; and
- b. within the distortions and disturbances specified in these technical requirements.

The DNSP does not guarantee the operation of any customer appliances, including Small IES Units and their associated components. The Proponent shall take necessary steps to ensure their Small IES Unit operates as anticipated and also adhere to their applicable customer connection contract.

The DNSP may inspect Dynamic Small IES at any time at the DNSP's expense.

### 7.2 Dynamic operation

A Dynamic Small IES shall be operated in fixed or dynamic limits as per Table 13.

**Table 13 Dynamic operation criteria**

Operational function	Requirements
Fixed limits	<ul style="list-style-type: none"> <li>• Connection contract for aDynamic Small IES.</li> <li>• Installed in compliance with this Standard.</li> </ul>
Dynamic limits	<ul style="list-style-type: none"> <li>• Connection contract for aDynamic Small IES.</li> <li>• Installed in compliance with this Standard.</li> <li>• Registered to the DNSP IEEE SEP2 Utility Server.</li> <li>• Receive dynamic Export and Import limits.</li> <li>• Operate Dynamic Small IES to meet Export and Import limits.</li> </ul>

# Dynamic Standard for Small IES Connections



## Appendix A: Deviations from the National DER Connection Guidelines (informative)

There are no current National DER Connection Guidelines for dynamic connections. This Standard has been developed in alignment with the framework of the National DER Connection Guidelines.

# Dynamic Standard for Small IES Connections

## Appendix B: Connection arrangement requirements (normative)

Following is a representation for a Small IES Unit installation as considered in this Standard.

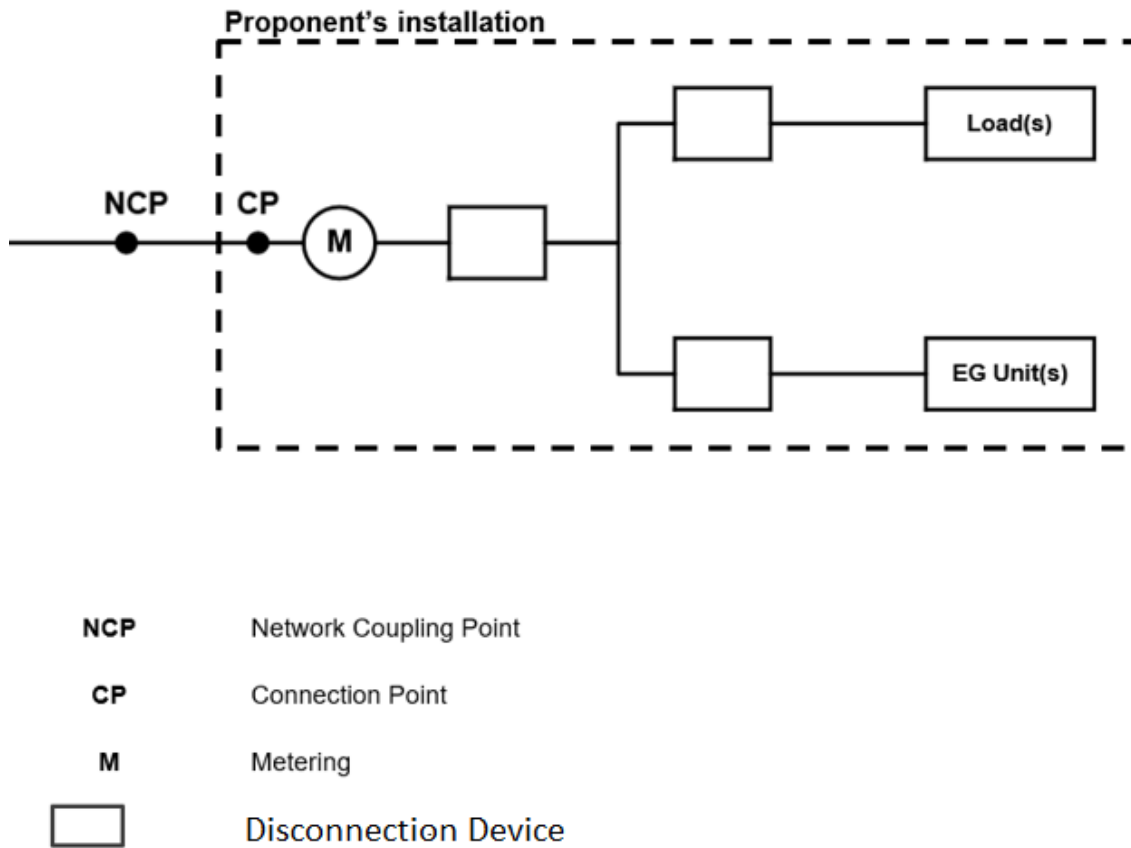

Figure 3: Small IES Dynamic EG Connection installation representation

# Dynamic Standard for Small IES Connections



## Appendix C: Model Standing Offer (informative)

This section has been left intentionally blank.

# Dynamic Standard for Small IES Connections

## Appendix D: Static data and information (informative)

Static data and information shall be provided by the Proponent to the DNSP based on your application type and may include some of the following below (but not limited to):

1. NMI and physical meter number(s).
2. System information:
  - a. Detailed single line diagram demonstrating motors, large loads, EG Units connected, and proposed for connection, at the Premises (including detail of any interlocking).
  - b. Number of phases available.
  - c. Energy source.
  - d. Maximum demand, capacity, and output rating.
  - e. Any proposed export limit for DER (Full / Partial- / Non- / minimal) and method of export control.
  - f. Metering scheme information (gross or net).
3. Inverter
  - a. Make. Model and manufacturer
  - b. Number installed
  - c. Power quality modes
4. Other Device information:
  - a. Type (e.g., motor, pump, mill, chiller, panel, battery).
  - b. Make, model and manufacturer.
  - c. Number installed.
5. Applicant and Customer information:
  - a. Type.
  - b. Full customer name or name of other legal entity capable of contracting with the DNSP.
  - c. Retail Customer / Retail Account Holder
  - d. Address and contact information.
6. Electrical Contractor, RPEQ, Consultant and/or Installer information.
7. Dynamic DER Registration information.

# Dynamic Standard for Small IES Connections

## Appendix E: Dynamic data and information (informative)

Dynamic data and information shall be provided by the Proponent to the DNSP or by the DNSP to the Proponent based on the application type and may include (but is not limited to) the following:

**Table 14 Dynamic monitoring information via CSIP-AUS**

Measurement	Data Qualifier	Site	DER <sup>1</sup>
Real Power (W/phase)	Average	Mandatory	Mandatory
Reactive Power (Var/phase)	Average	Mandatory	Mandatory
Voltage (V/phase)	Average	Mandatory	Optional

Note 1 – Measurements from Metering Mirror function set.

Note 2 – DER telemetry is total of aggregated actively managed devices.

Note 3 – At least one site or device voltage must be reported. Where site voltage is available, it must be reported.

**Table 15 Dynamic control functions via CSIP-AUS**

Category	Support Function	DER control requirements
Export limit	DERControlBase within the DERControl.	DERControlBase:csipaus:opModExpLimW (Watts)
Import limit	DERControlBase within the DERControl.	DERControlBase:csipaus:opModImpLimW
Actively Managed Load limit	DERControlBase within the DERControl.	DERControlBase:csipaus:opModLoadLimW
Generation limit	DERControlBase within the DERControl.	DERControlBase:csipaus:opModGenLimW and DERControl:opModEnergize
Forecasting <sup>1</sup>	Forecasting using DERControl.	Using DERControl events
Loss of communications revert to fixed limits	DefaultDERControl.	<i>DefaultDERControl; and setGradW</i>

Note 1 – Capable of supporting a minimum of five-minute interval envelope events for the next hour and thirty-minute interval events for the following 23 hours, updated every five minutes under normal circumstances. (58 events per connection point).



# Dynamic Standard for Small IES Connections

## Appendix F: Compliance checklist (informative)

The purpose of this compliance checklist is to aid the Proponent with the design and commissioning of the Small IES Unit to ensure it meets the relevant requirements, as set out in this Standard.

Registration to the SEP2 utility server is required to support dynamic operation within dynamic Export and Import limits.

**Table 16 General Inverter Settings**

Parameter	Settings	Australia A Region
V <sub>nom_max</sub>	258 V	Default 'Australia A' region settings
Volt-var settings (refer to Table 9)	V <sub>V1</sub> = 207 V; 44% supplying V <sub>V2</sub> = 220 V; 0% V <sub>V3</sub> = 240 V; 0% V <sub>V4</sub> = 258 V; 60% absorbing	
Volt-watt settings (refer to Table 10)	V <sub>W1</sub> = 253 V; 100% V <sub>W2</sub> = 260 V; 20%	
Volt-watt settings for energy storage when charging (refer to Table 11)	V <sub>W1-ch</sub> = 207 V; 20% V <sub>W2-ch</sub> = 215 V; 100%	
Reconnect time	60 seconds	

**Table 17 Disconnection Times**

Parameter	Settings	Trip Time Delay	Maximum Disconnection Time	Australia A Region
Overvoltage 1 (V>)	265 V	1 s	2 s	Default 'Australia A' region settings
Overvoltage 2 (V>>)	275 V	-	0.2 s	
Undervoltage 1 (V<)	180 V	10 s	11 s	
Undervoltage 2 (V<<)	70 V	1 s	2 s	
Overfrequency (F>)	52 Hz	-	0.2 s	
Underfrequency (F<)	47 Hz	1 s	2 s	

**Table 18 Power Limiting Settings**

Parameter	Settings
Export Power Limit	As approved
Maximum response time	15 s

# Dynamic Standard for Small IES Connections

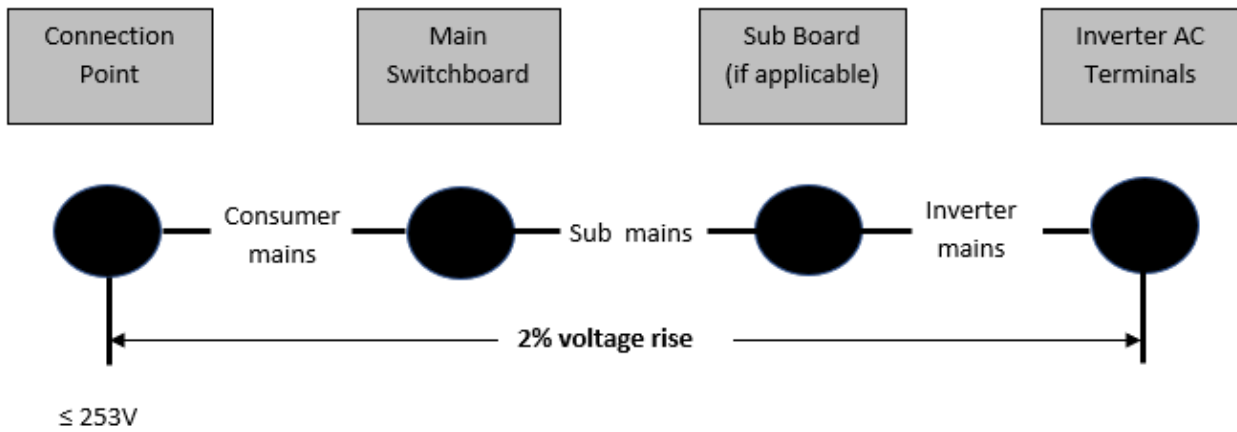

Figure 4 Voltage Rise Calculation Diagram

Table 19 Calculated voltage rise

Voltage rise	Consumer mains	Submains	Inverter mains	Total voltage rise
Calculated (V)				
Percentage (%)				

# Dynamic Standard for Small IES Connections

## Appendix G: Small IES Dynamic EG Connection types (informative)

**Table 20 Connection types - Small IES Dynamic EG Connections to Energex and Ergon Energy Network LV Distribution System**

Connection types <sup>1</sup>		Capacity	Export <sup>3</sup>		Import <sup>4</sup>		Contract type
		Maximum capacity limit where dynamic operation is enabled	Fixed Default dynamic Export limit	Maximum dynamic Export limit	Fixed Default dynamic Import limit	Maximum dynamic Import limit	
Single-phase		≤ 10 kVA PV & ≤ 10 kVA ESS	1.5 kW	10 kW	1.5 kW	18 kW	Negotiated
Two-phase		≤ 5 kVA PV & ≤ 5 kVA ESS per phase <sup>2</sup>	1.5 kW	10 kW per phase <sup>2</sup>	1.5 kW	10 kW per phase <sup>2</sup>	Negotiated
Three-phase		≤ 10 kVA per phase <sup>2</sup>	1.5 kW	10 kW per phase <sup>2</sup>	1.5 kW	10 kW per phase <sup>2</sup>	Negotiated
SWER	Single-phase	≤ 15 kVA PV & ≤ 15 kVA ESS	1.5 kW	≤ 10 kW	1.5 kW	10 kW	Negotiated
	Split-phase	≤ 5 kVA PV & ≤ 5 kVA ESS per phase <sup>2</sup>	1.5 kW	≤ 10 kW per phase <sup>2</sup>	1.5 kW	10 kW per phase <sup>2</sup>	Negotiated

Note 1: These limits shall be considered applicable to the aggregate of all Small IES Dynamic Connections at a Premises, including Premises with more than one LV Connection Point and where a Proponent is seeking connection to the Distribution System at more than one LV Connection Point.

Note 2: Multiphase EG Systems have phase balance requirements as per Section 4.3.5 of this Standard.

Note 3: Default Export limits are as per Section 4.3.1.

Note 4: Total Import limit by a Proponent at the Connection Point shall meet the requirements of a Proponent's network customer connection contract for supply. The operation of Import limits shall not enable a Proponent to exceed the maximum supply limits for the Premises under the applicable customer connection contract.



Part of Energy Queensland

[ergon.com.au](http://ergon.com.au)  
[energex.com.au](http://energex.com.au)

PO Box 1090, Townsville QLD 4810  
GPO Box 1461, Brisbane QLD 4001

Ergon Energy Network  
ABN 50 087 646 062  
Energex is the trading name of  
Energex Limited  
ABN 40 078 849 055